

***Notes:**
Operator, Arm, Edge and Traffic Lights are Sold Separately.

***Anchor bolts Are NOT Provided.**
3/4 in - 1.0 in Diameter Anchor Bolts (65) are Recommended.

REVISIONS			
REV.	DESCRIPTION	DATE	APPROVED
A	New Number	5/1/2024	Tpham
B	Sheet 4: 1601-174 bolt was 1601-165; 2615-260 bolt was 2615-053; removed 2620-029 washer and 2620-047 washer	10/29/2024	Tpham

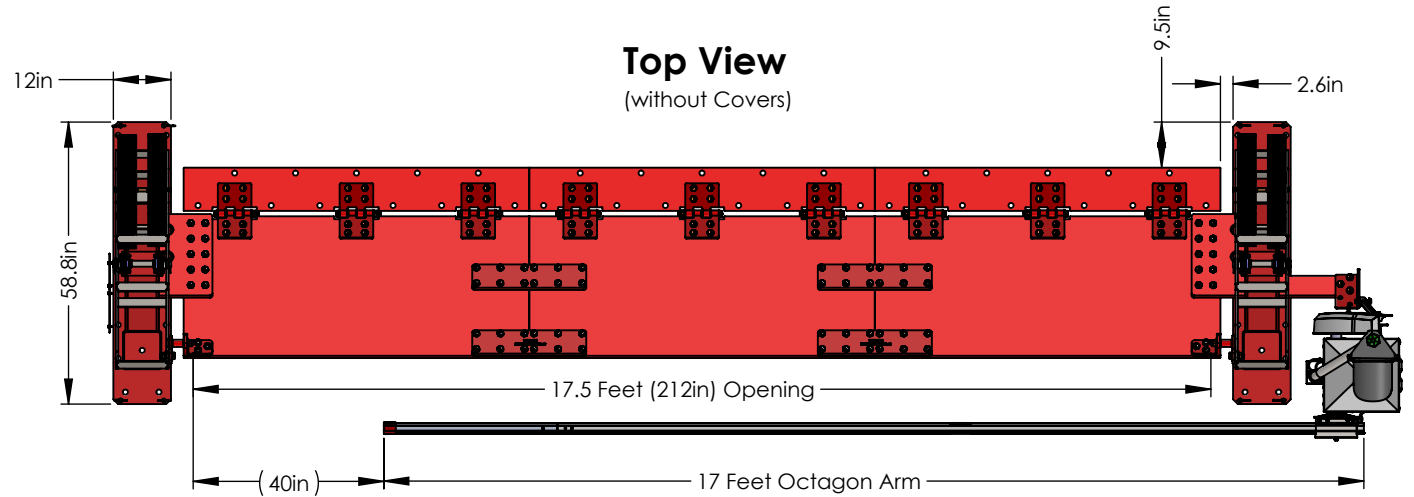

Side View
(without Covers)

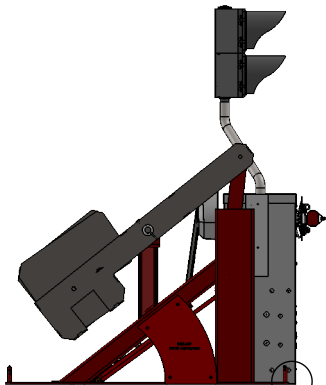

Front View
(without Covers)

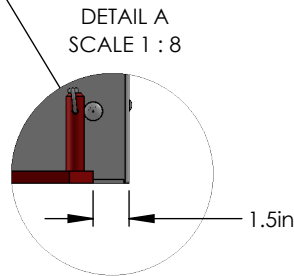
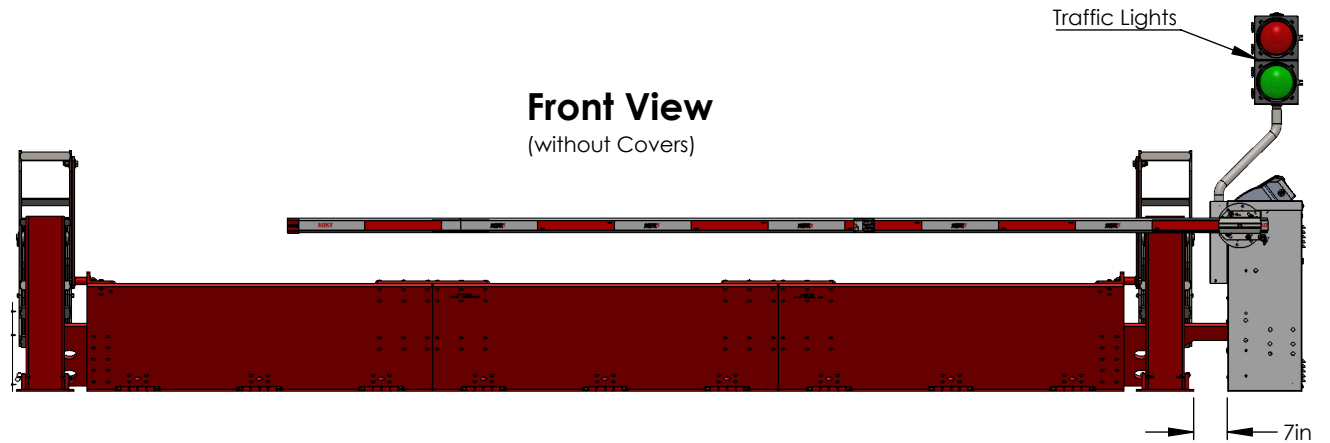

DRAWN	Tpham		DWG. NO.	1625-618	REV.	B
DATE	05/01/24		WHERE USED			
NAME	Wedge Barrier 18FT Bolt					
PROPRIETARY & CONFIDENTIAL: The information contained in this drawing is the sole property of DoorKing, Inc. Any reproduction in part or as a whole without written permission of DoorKing, Inc. is prohibited.						
DO NOT SCALE TO DRAWING		SHEET SIZE	A	SCALE: 1:100	SHEET 1 OF 5	

PartNo	Description	QTY.
1200-010	Hinge Bearing	4
1601-097	Hub Bolt Lock Washer	1
1601-174	1/2-13 UNC x 2.0" Hex Hd Bolt	1
1601-208	Cap Octagonal Spring Lock	1
1620-006	Pin Cotter Hairpin SS	8
1625-005	Link Bar	2
1625-105	Connecting Link Assy for Wedge	1
1625-218	Plate 0.375" Thick x 18.5" x 22"	40
1625-223	Hinge Assembly	9
1625-281	Cover Left Hub Plastic	1
1625-282	Cover Right Hub Plastic	1
1625-522	Wedge Side Plate	1
1625-528	Wedge Operator Side Plate	1
1625-529	Wedge Operator Side Pivot	1
1625-533	Wedge Joint Plate	4
1625-536	Pivot Side Hinge	2
1625-560	Wedge Post	2
1625-580	Wedge Cover Right	1
1625-581	Wedge Cover Left	1
1625-586	Rod Shaft 1.25 O.D. x 12.5 Length	2
1625-598	Hub Weld Assy	1
1625-604	Nut M20 x 2.5 Nylon Lock Class 10.9	4
1625-606	Self Tap Screw 1/4-14 x 3/4 in Hex Hd	4
1625-609	Cover Outside Cutout	1
1625-620	Wedge Center Plate 6ft	1
1625-621	Wedge Main Plate 6ft	2
1625-651	Anchor Plate 6ft	3
1625-688	Bearing 20x42x12mm 6004-2RS	4
1625-690	Wedge Weight Basket	2
1625-701	Cotter Pin 1/4 x 2.0" Chrom	4
1625-702	Bolt 1/2-13 x 11.5in L SS Hex Hd	2
1625-713	Washer 3/4 IDx2.0 ODx0.12 Thick	12
1625-716	Bolt Hex Head 7/16-14 x 1.75 Gr8 Zinc	8
1625-716	Bolt Hex Head 7/16-14 x 1.75 Gr8 Zinc	8
1625-719	Washer 20mmID x 30mmOD x 0.03in Thick	8
1625-720	Hex Hd M20x2.5mmx30mm Class10.9	75
1625-721	Bolt Hex Hd M20x2.5mmx40mm	74
1625-805	Bolt Hex M20 x 2.5mm x 65mm Gr10.9	2
1625-806	Bolt Hex Hd M20x2.5mmx130mm Gr10.9	1
1625-806	Bolt Hex Hd M20x1.5mmx130mm Gr10.9	1
2600-038	Spacer .75 OD x .50 ID x 2.0 L	2
2600-147	Spacer Steel .75 OD x .53 ID x .56 L	1
2615-186	Bolt Hex hd 1/2-13 x 3" Grd 8	2
2615-260	18-8 SS Flange Head Cap Screw 3/8"-16 Thread, 1/2" Length, Fully Threaded	1
2616-052	Screw 10-32 x 1/2 Phillips Head	1
2620-030	Washer 1/2 ID USS	5
2620-220	Washer 1.25IDx2.25ODx0.05Thick	8
2620-320	Nut 1/2-13 Center Lock	4
2620-407	Nut Hex 7/16-14	16

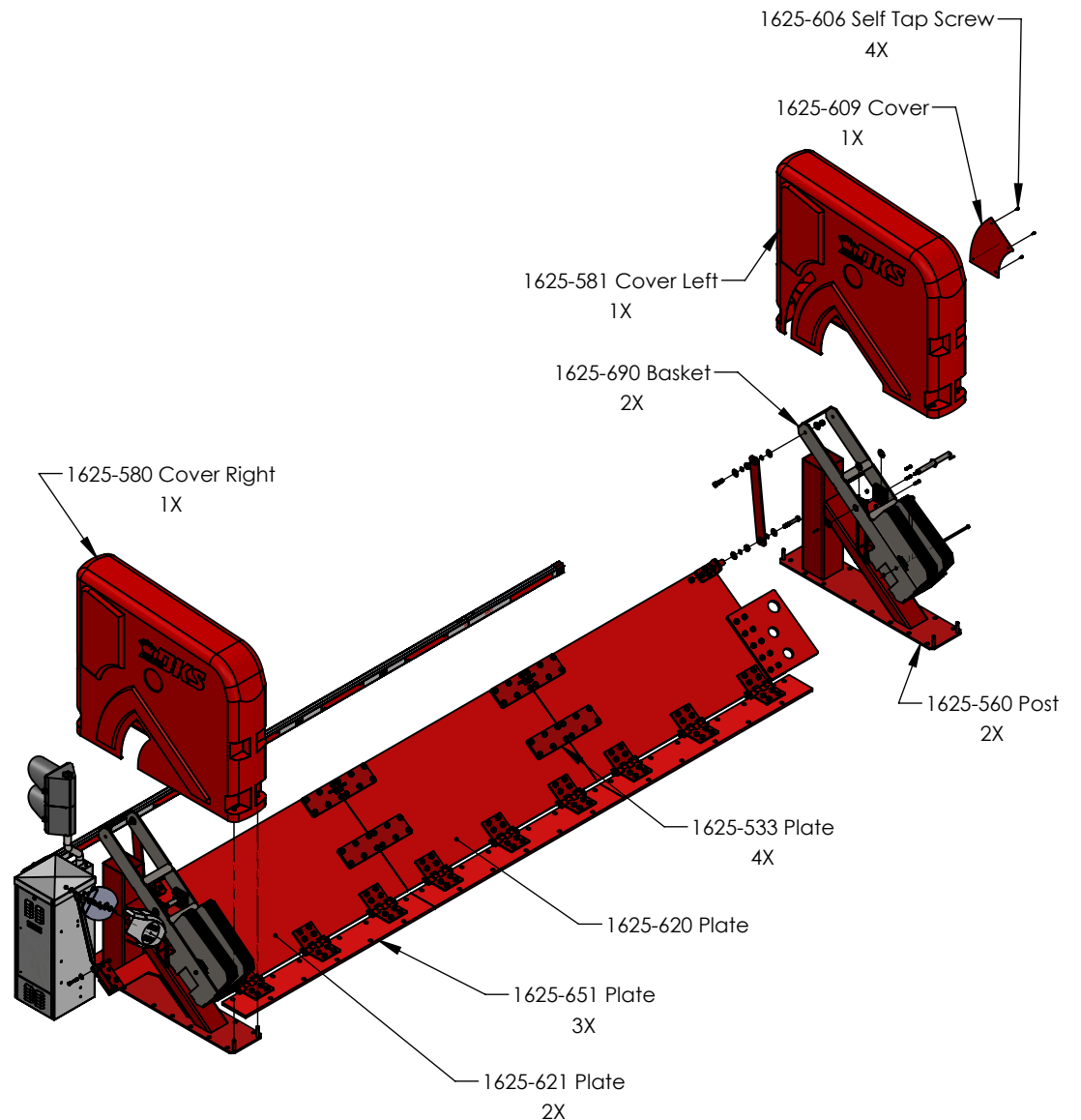

DRAWN	Tpham		DWG. NO.	1625-618	REV.	B
DATE	05/01/24		WHERE USED			
NAME	Wedge Barrier 18FT Bolt					
PROPRIETARY & CONFIDENTIAL: The information contained in this drawing is the sole property of DoorKing, Inc. Any reproduction in part or as a whole without written permission of DoorKing, Inc. is prohibited.						
DO NOT SCALE TO DRAWING		SHEET SIZE	A	SCALE: 1:100	SHEET 2 OF 5	

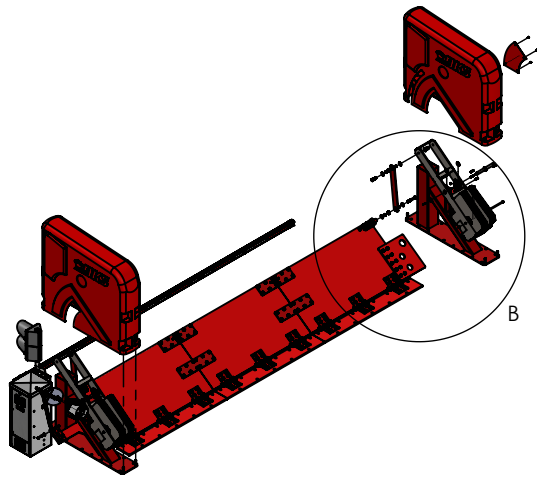

DETAIL B
SCALE 1 : 15

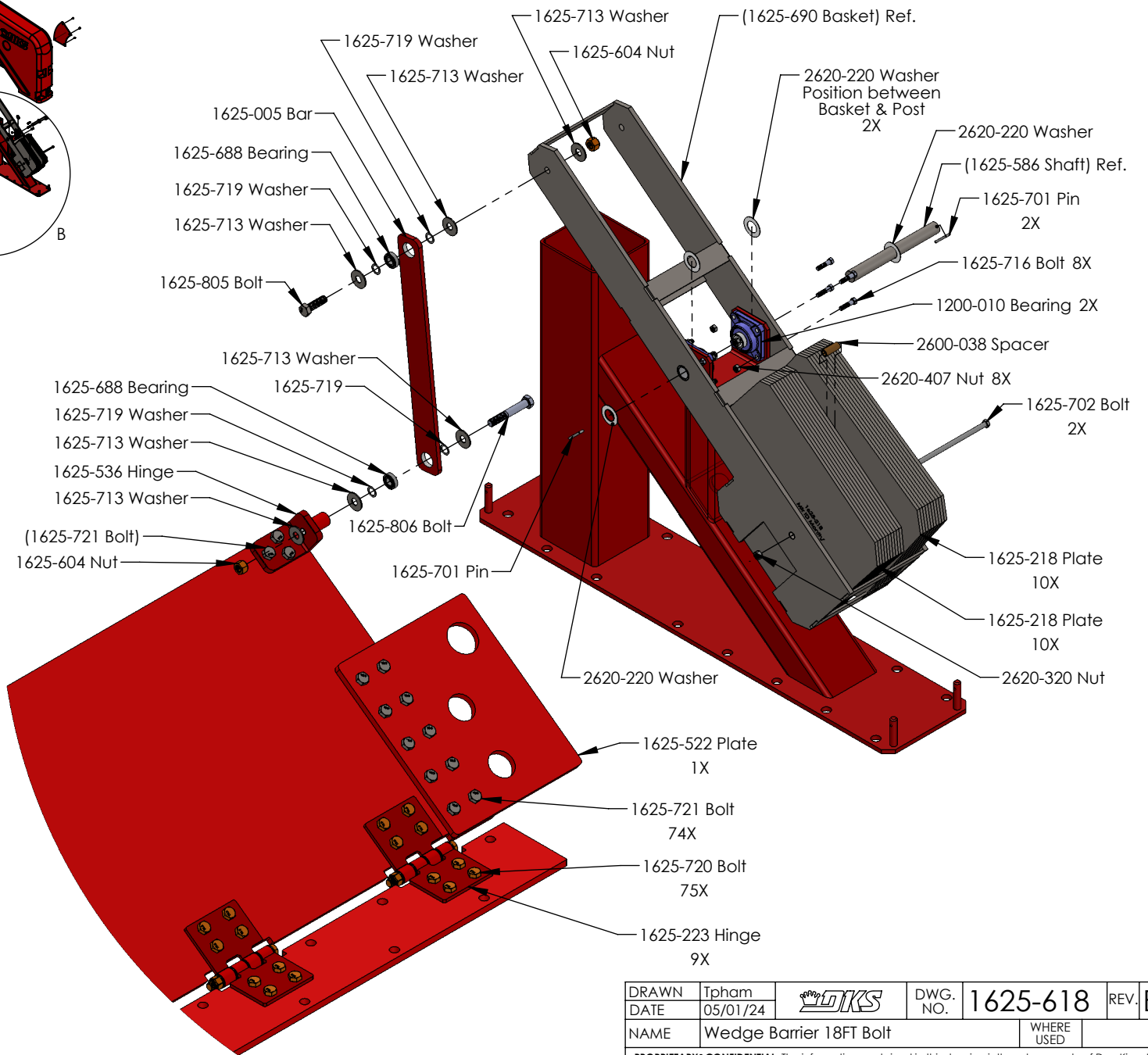

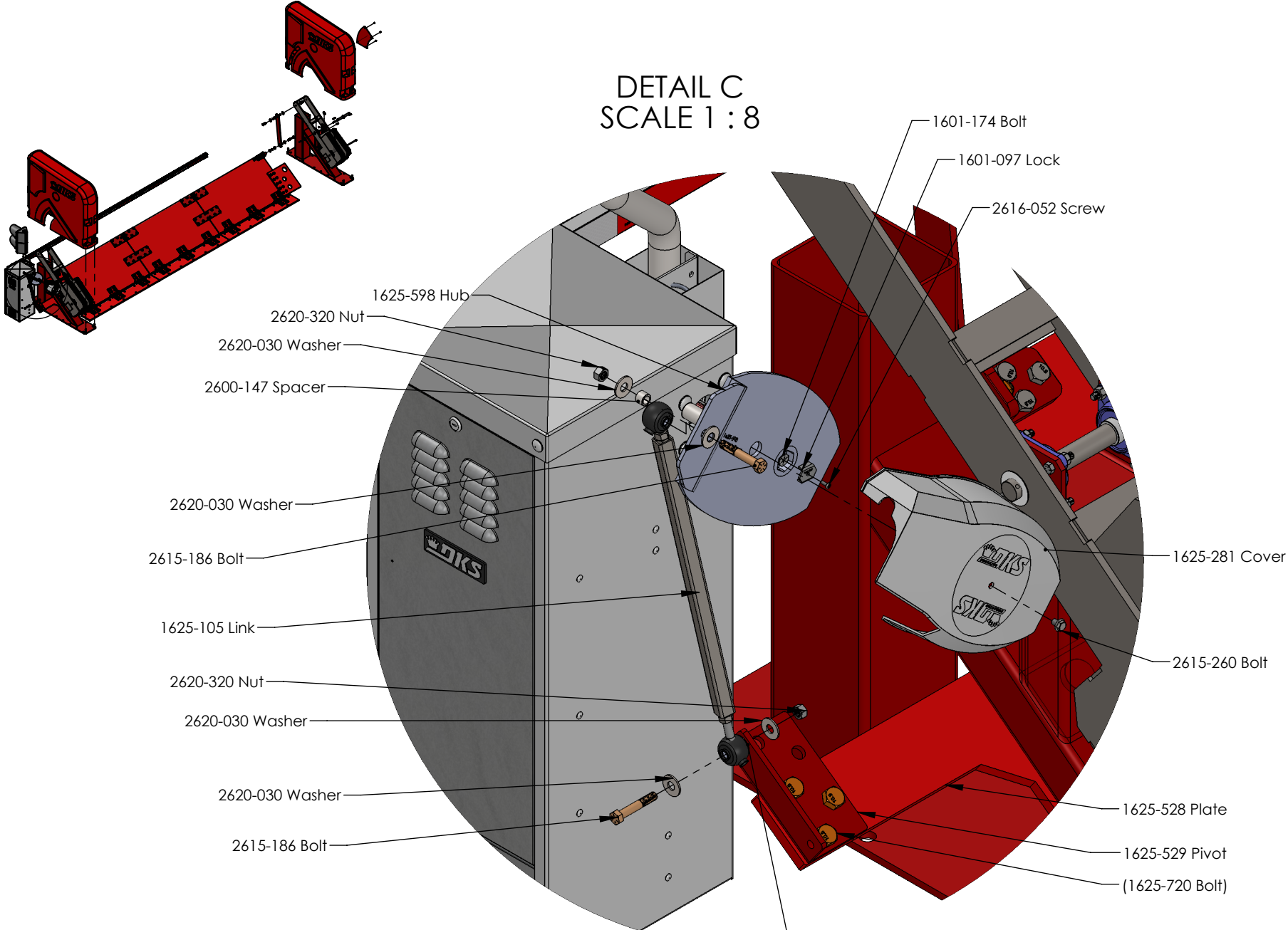

DRAWN	Tpham		DWG. NO.	1625-618	REV.	B
DATE	05/01/24		WHERE USED			
NAME	Wedge Barrier 18FT Bolt					
<small>PROPRIETARY & CONFIDENTIAL: The information contained in this drawing is the sole property of DoorKing, Inc. Any reproduction in part or as a whole without written permission of DoorKing, Inc. is prohibited.</small>						
DO NOT SCALE TO DRAWING		SHEET SIZE	A	SCALE: 1:100	SHEET 3 OF 5	

DETAIL C
SCALE 1 : 8

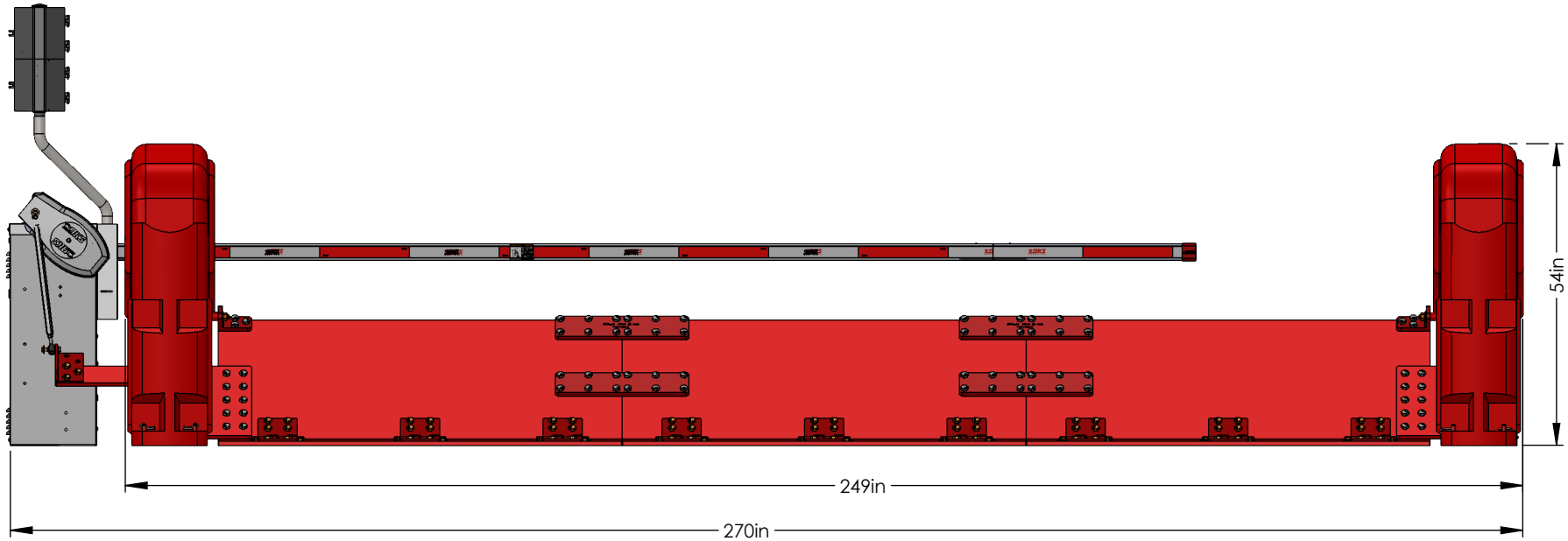
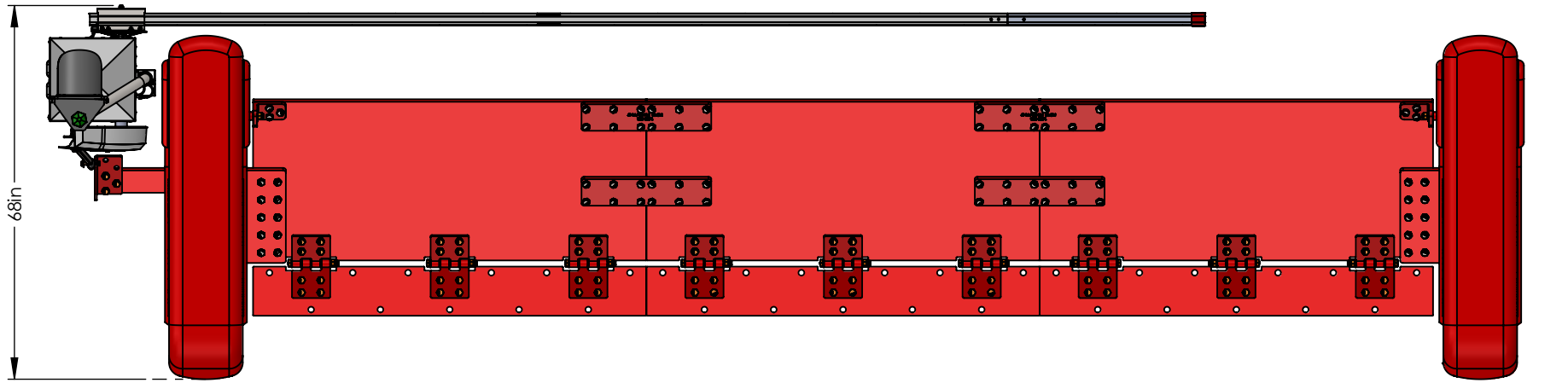

DRAWN	Tpham		DWG. NO.	1625-618	REV.	B
DATE	05/01/24		NAME	Wedge Barrier 18FT Bolt	WHERE USED	
<p>PROPRIETARY & CONFIDENTIAL: The information contained in this drawing is the sole property of DoorKing, Inc. Any reproduction in part or as a whole without written permission of DoorKing, Inc. is prohibited.</p>						
DO NOT SCALE TO DRAWING			SHEET SIZE	A	SCALE: 1:100	SHEET 4 OF 5



DRAWN	Tpham		DWG. NO.	1625-618	REV.	B
DATE	05/01/24		WHERE USED			
NAME	Wedge Barrier 18FT Bolt					
PROPRIETARY & CONFIDENTIAL: The information contained in this drawing is the sole property of DoorKing, Inc. Any reproduction in part or as a whole without written permission of DoorKing, Inc. is prohibited.						
DO NOT SCALE TO DRAWING		SHEET SIZE	A	SCALE: 1:100	SHEET 5 OF 5	