

REVISIONS

REV.	DESCRIPTION	DATE	APPROVED
A	New Breakaway Hardware Kit for Octagonal Arm	11/22/19	Tpham
B	Sheet 2: Added 8080-105 Rubber Bumper	02/10/20	Tpham
E	1601-244 Plate was 1601-291	06/22/21	Tpham
F	Sheet 2: 1601-426 Open Transformer was 1601-422 PlugIn Transformer; Added: 2904-002 Screw 2X, 2616-053 Screw 2X, 1601-186 Mount;	7/28/2021	Tpham
G	Added to sheet 2: 1601-206 Rev C	8/25/2022	Tpham
H	Sheet 2: 1601-203 stopper replaced 8080-105 spacer; 1601-340 Steel Hub was 1601-079; Added 1804-031 Tie 3X; 2902-004 Nut 3X, 2600-619 clip 1X; 1804-029 2X	12/13/2023	Tpham

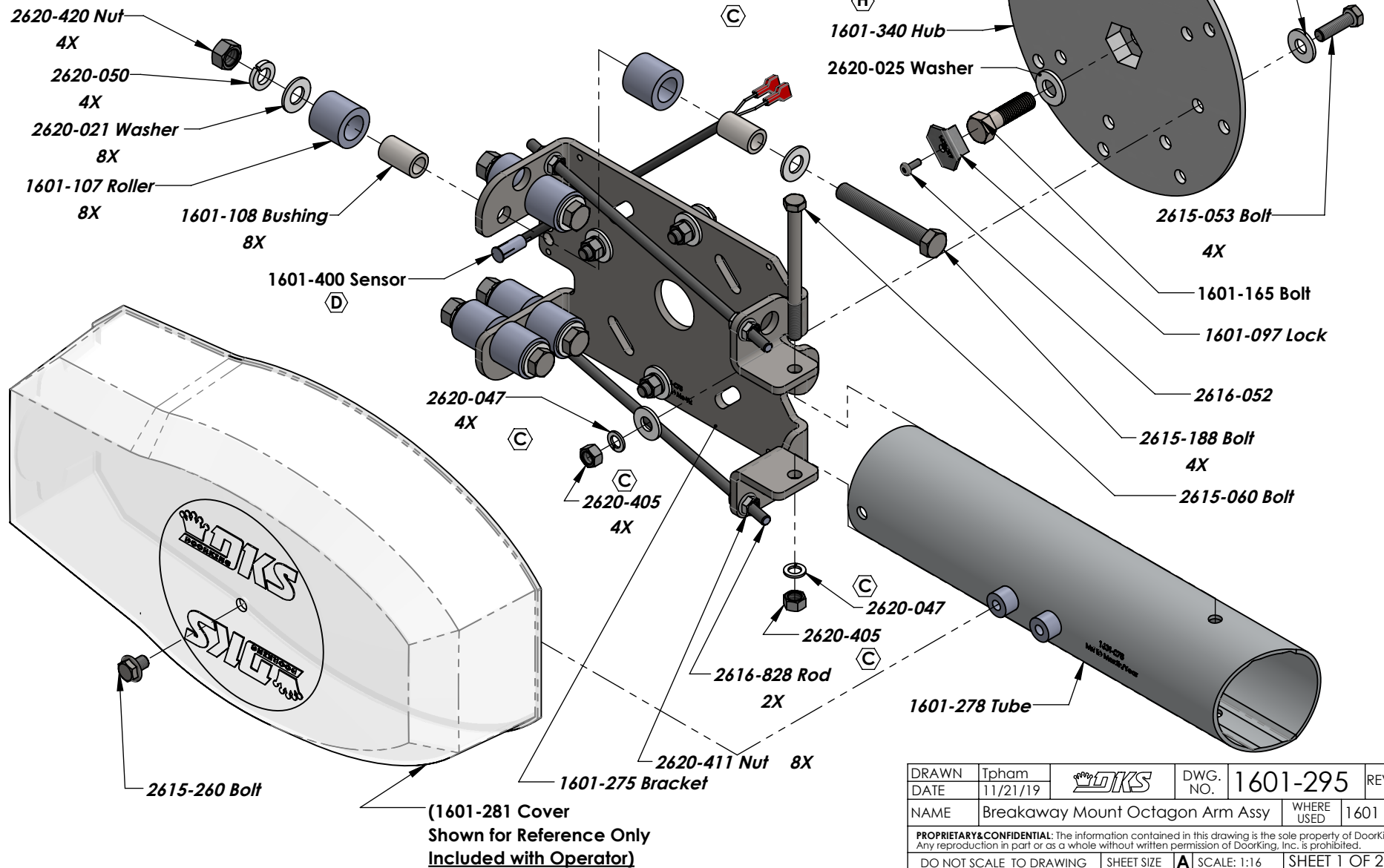

DRAWN	Tpham		DWG. NO.	1601-295	REV.	H
DATE	11/21/19		WHERE USED	1601		
NAME	Breakaway Mount Octagon Arm Assy		PROPRIETARY & CONFIDENTIAL: The information contained in this drawing is the sole property of DoorKing, Inc. Any reproduction in part or as a whole without written permission of DoorKing, Inc. is prohibited.			
DO NOT SCALE TO DRAWING		SHEET SIZE	A	SCALE: 1:16	SHEET 1 OF 2	

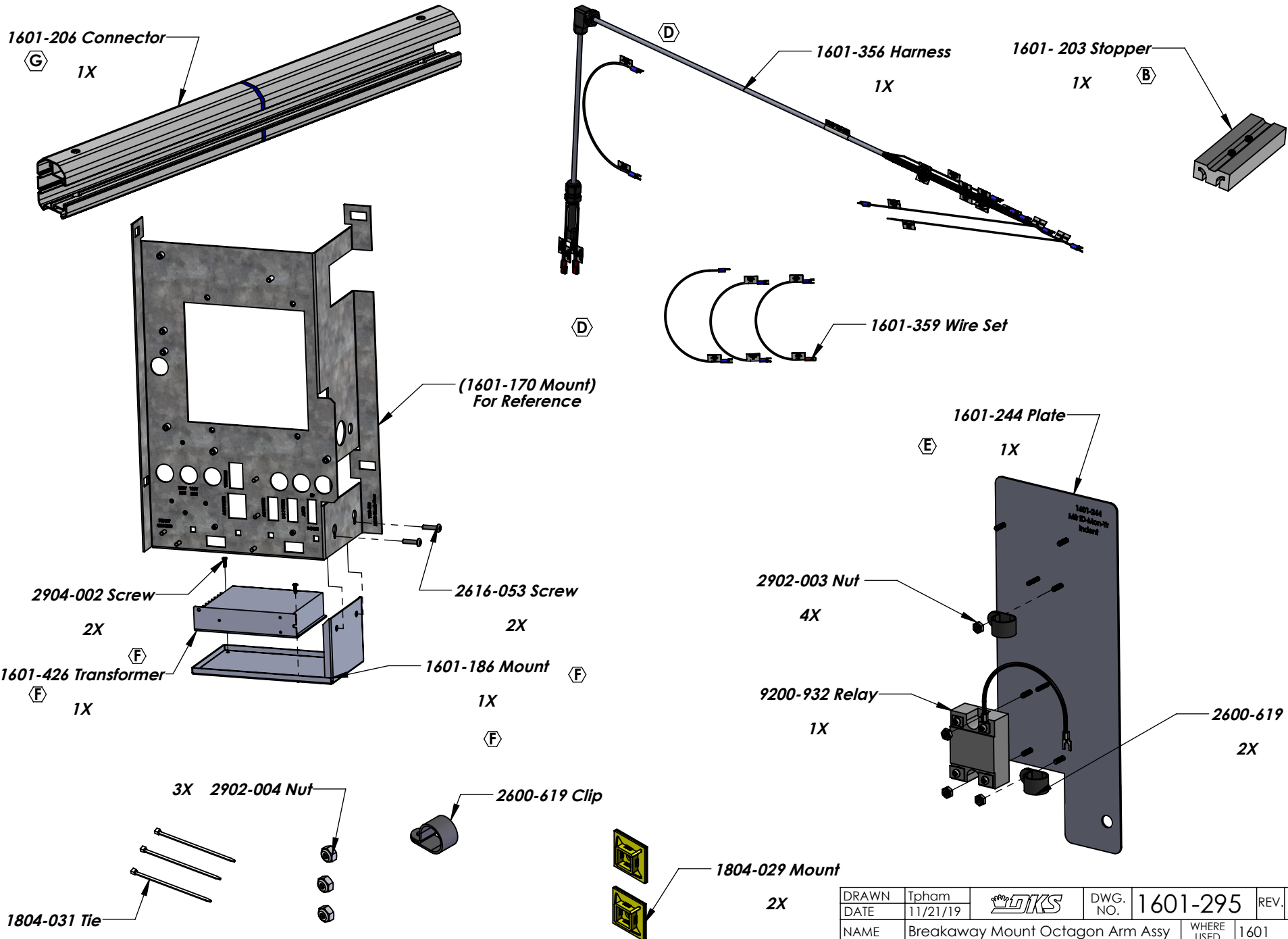

DRAWN	Tpham		DWG. NO.	1601-295	REV.	H
DATE	11/21/19		WHERE USED	1601		
NAME			Breakaway Mount Octagon Arm Assy			
<small>PROPRIETARY & CONFIDENTIAL: The information contained in this drawing is the sole property of DoorKing, Inc. Any reproduction in part or as a whole without written permission of DoorKing, Inc. is prohibited.</small>						
DO NOT SCALE TO DRAWING			SHEET SIZE	A	SCALE:	1:16
			SHEET 2 OF 2			