

1601 /1602 BREAK-AWAY BRACKET FOR HIGH WINDS

DoorKing Part Number
1601-297

This kit is designed for 1601 or 1602 **break-away** barrier gate operators **ONLY**. It **CANNOT** be used with 1603 operators (break-away arm is **NOT** an option with the 1603). **The kit provides a bracket for an existing WHITE break-away arm assembly ONLY**. The silver zinc plated break-away arm assembly does **NOT** need this bracket. This bracket will stiffen the release rollers to prevent unwanted arm release that may occur during high winds, especially when using the octagon arm.

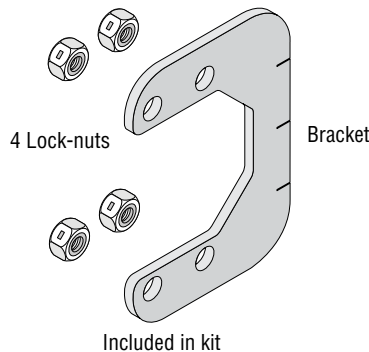

Installation

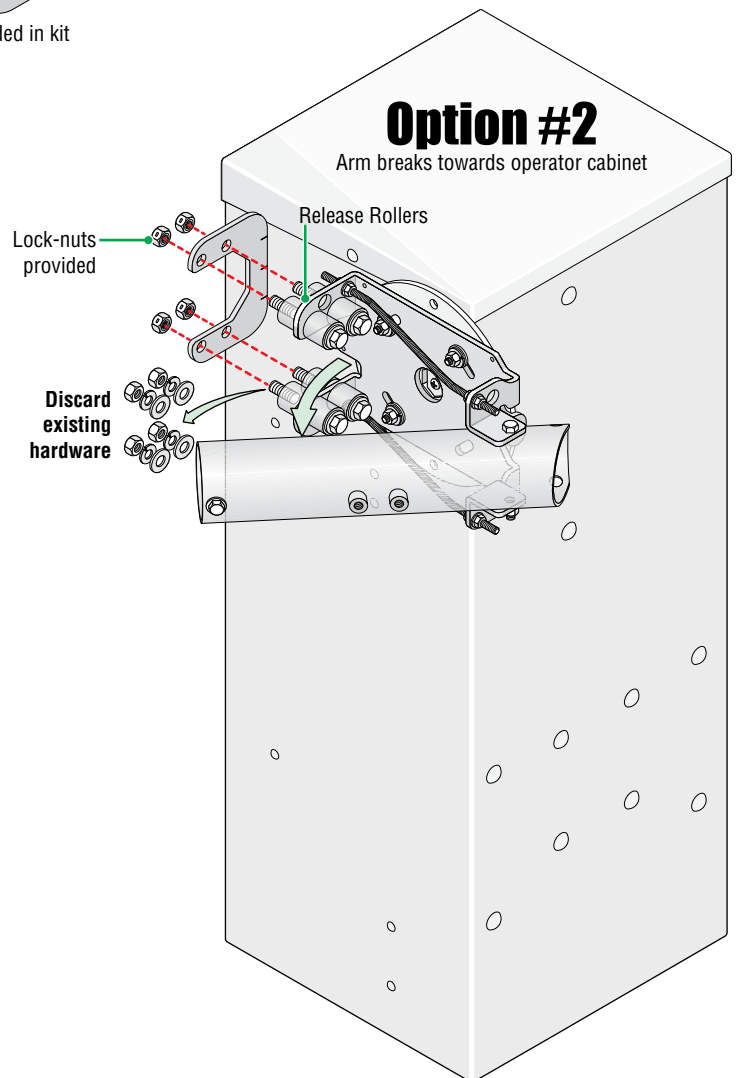
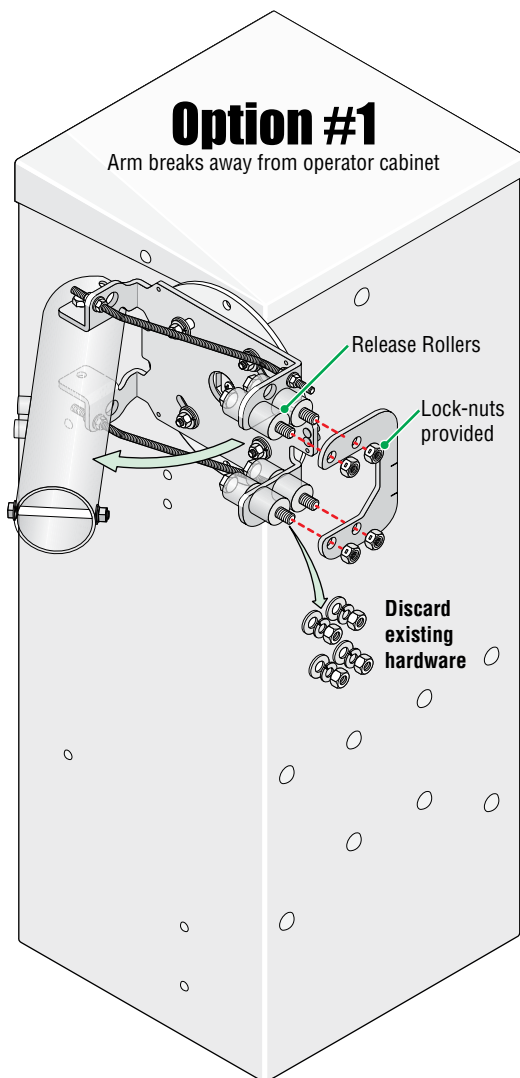

Remove the nuts, flat-washers and lock-washers from the (4) existing release roller bolts and **discard** .
Mount bracket on release roller's bolts and use lock-nuts included in this kit.

Use with **WHITE** Break-away
bracket **ONLY**

DKS
DOOR KING
120 S. Glasgow Avenue
Inglewood, California 90301 U.S.A.