

1601 / 1602 BREAK-AWAY OCTAGON ARM KIT

This kit is designed for the 1601 **OR** 1602 barrier gate operators **ONLY**. It **CANNOT** be used with the 1603 operators. The kit provides a break-away bracket assembly for a **octagon arm** (either 14 ft or 17 ft arm) with **OR** without reverse/LED edge. When the arm is raised, LEDs turn **GREEN**, then turns **RED** when lowered and remains **RED** in the down position. Arm will reverse if lowering and a obstruction is encountered. If the arm is struck and breaks away (will pivot in **ONE DIRECTION ONLY**, see below), gate operator will automatically shut down. The arm manually snaps back into the release rollers to function normally again.

Break-Away Octagon Arm Bracket Installation Steps:

1 Install Break-Away Bracket	2
2 Install Arm	3
3 Install Wire Harness (1601-356)	4
4 Cable Run Options	4
5 Attach Wire Harness to Break-Away Bracket	4
6 Mount Power Supply and Relay	5
7 Octagon Break-Away Arm - Wiring to Operator	6
8 Connect Arm to Wire Harness (1601-356)	7
9 Secure Wires to Break-Away Bracket	7
10 Break-Away Arm Reset Procedure	7
• 2-Ft Coupler Installation (Required) (Included)	8
• 14 Ft 2-Piece Arm Assembly (Optional) (Sold Separately)	9
• 14 Ft Reverse Edge / Red Green LED Installation (Optional) (Sold Separately)	10
• 14 Ft Rubber Bumper Installation (Optional) (Sold Separately)	11
• 17 Ft Octagon Arm Assembly for a 1602 ONLY (Optional) (Sold Separately)	12
- 15 Ft Reverse Edge / Red Green LED Installation on 17 Ft Arm ONLY (Optional) (Sold Separately)	13
Older Existing Arm Plastic Cover Modification (If Necessary)	14

Break-Away Arm Bracket Direction Options

Break-Away arm bracket will only pivot in **ONE DIRECTION** depending on which way the break-away arm bracket is installed.

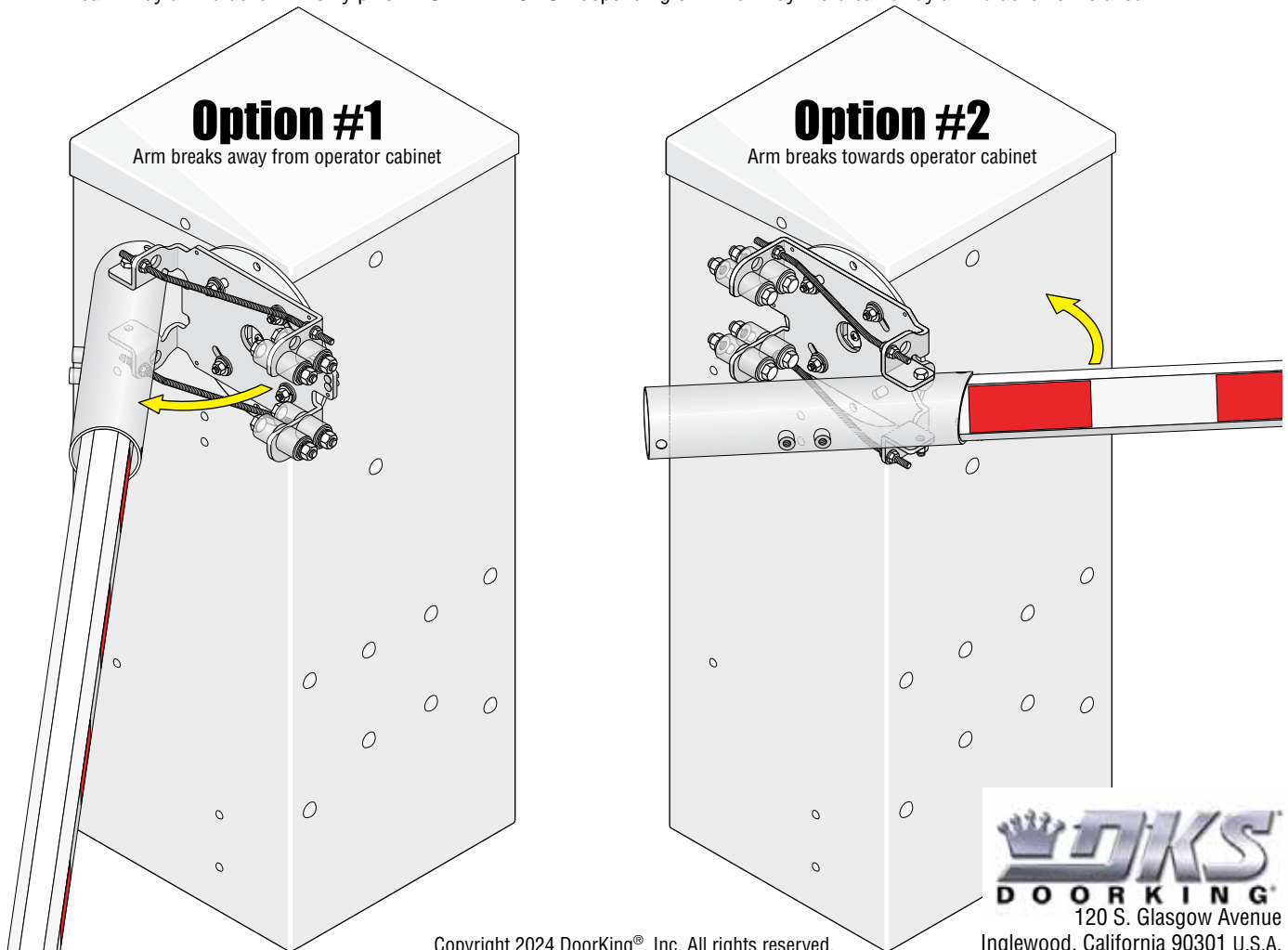

Break-Away Arm Direction Options

Arm will only pivot in **ONE DIRECTION** depending on which way the break-away arm bracket is installed. **Choose the desired break-away direction** and install break-away arm bracket accordingly (note position of **arm pivot bolt** and release rollers).

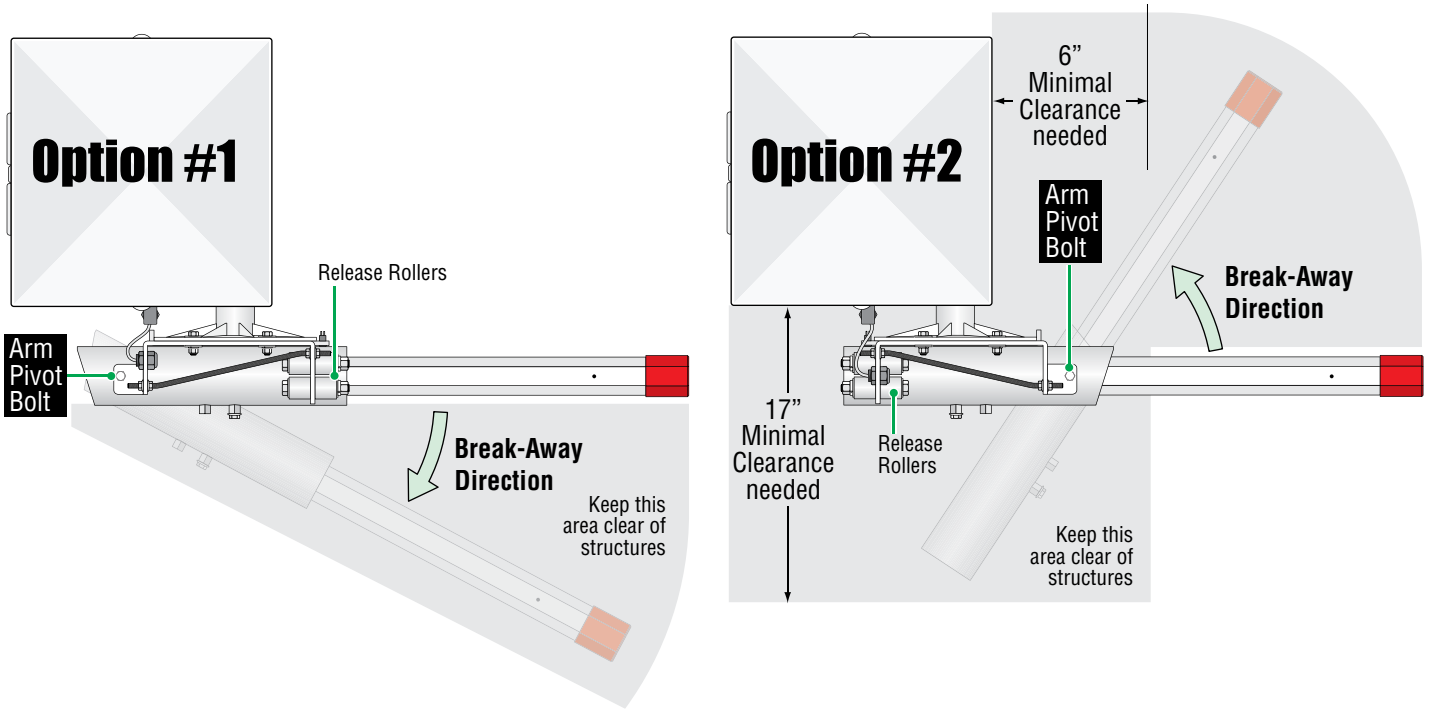

1 Install Break-Away Bracket

Hub **MUST** already be installed on barrier gate operator. See your 1601/1602 Barrier Installation/Owner's manual for correct hub installation.

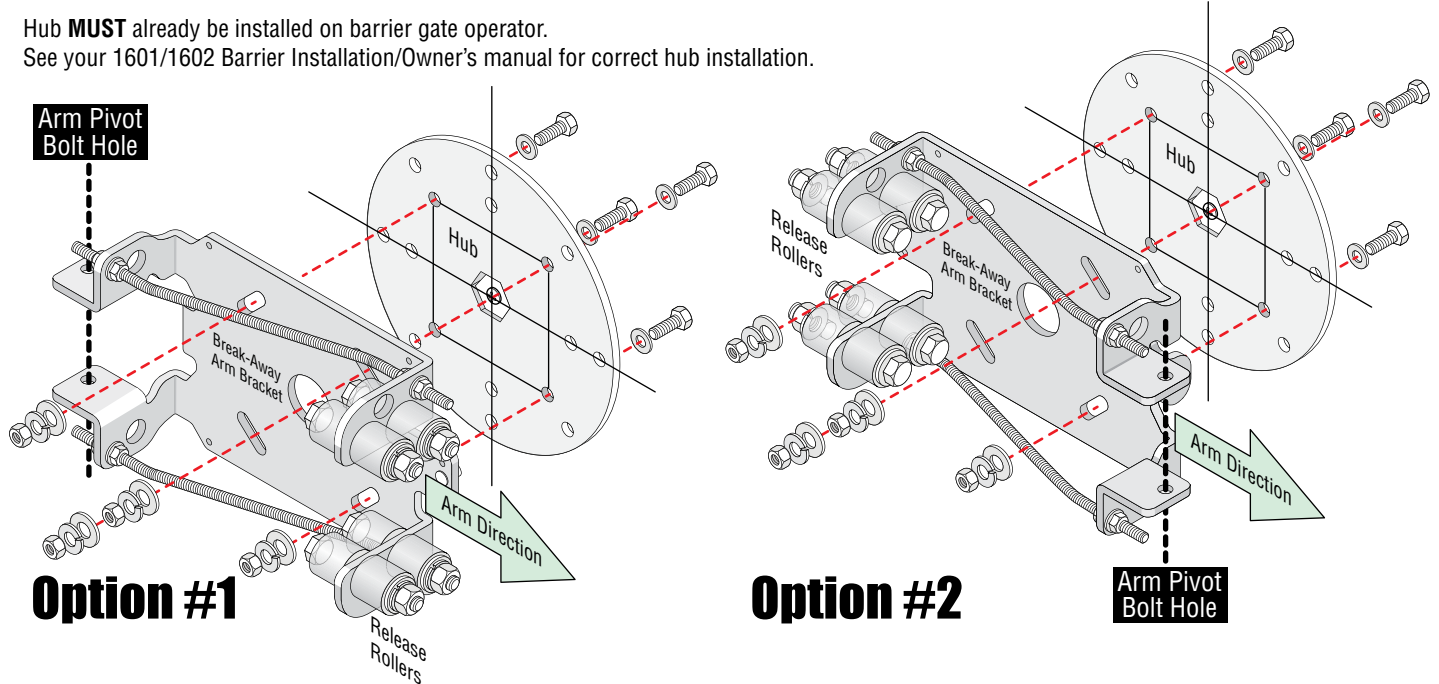

Test hub **UP** and **DOWN** position before installing bracket.

Hub is shown in the **DOWN** position in illustrations.

2 Install Arm

Arm sleeve snaps into release rollers.

3/8" Arm Pivot Bolt

Option #2

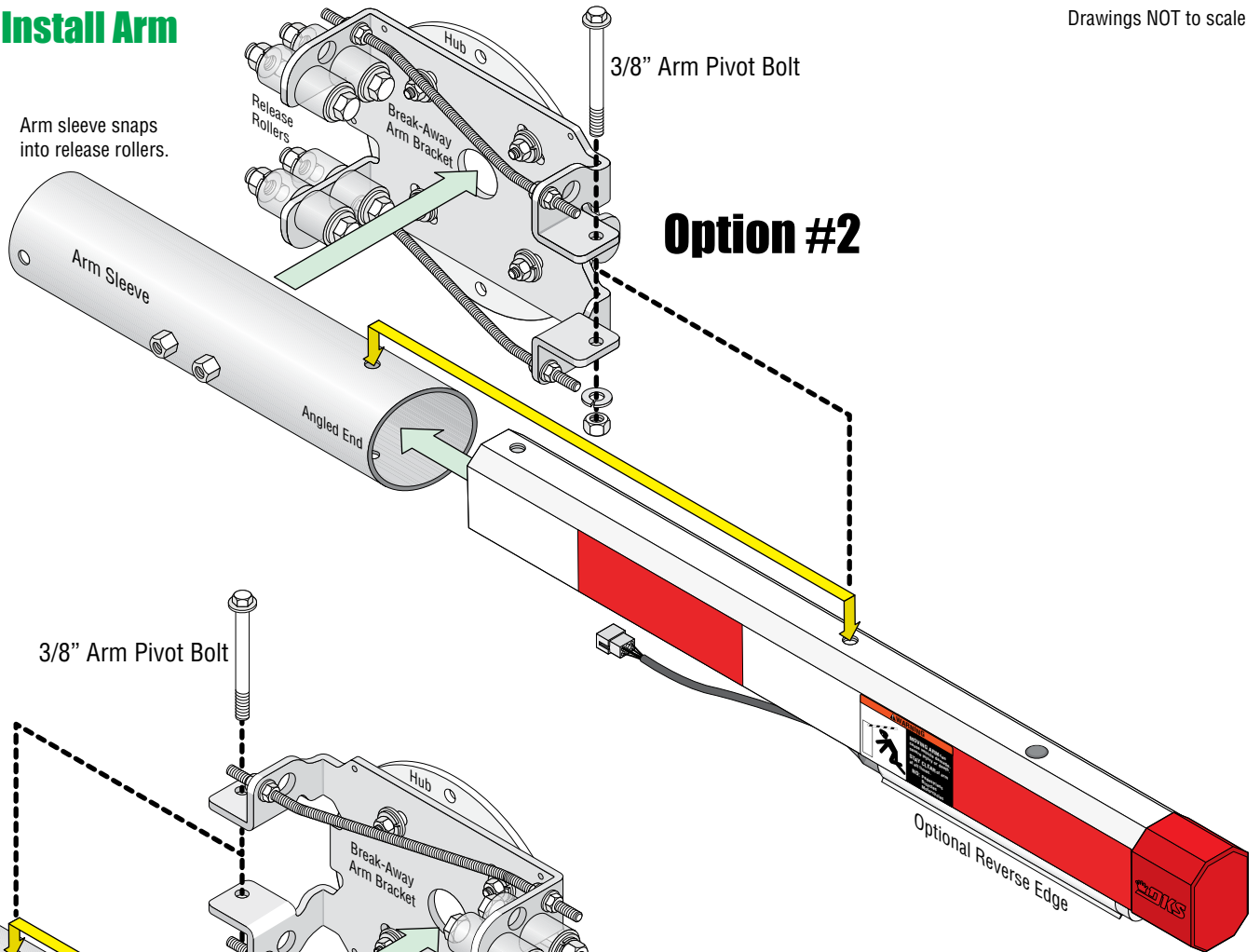

3/8" Arm Pivot Bolt

Option #1

Arm sleeve snaps into release rollers.

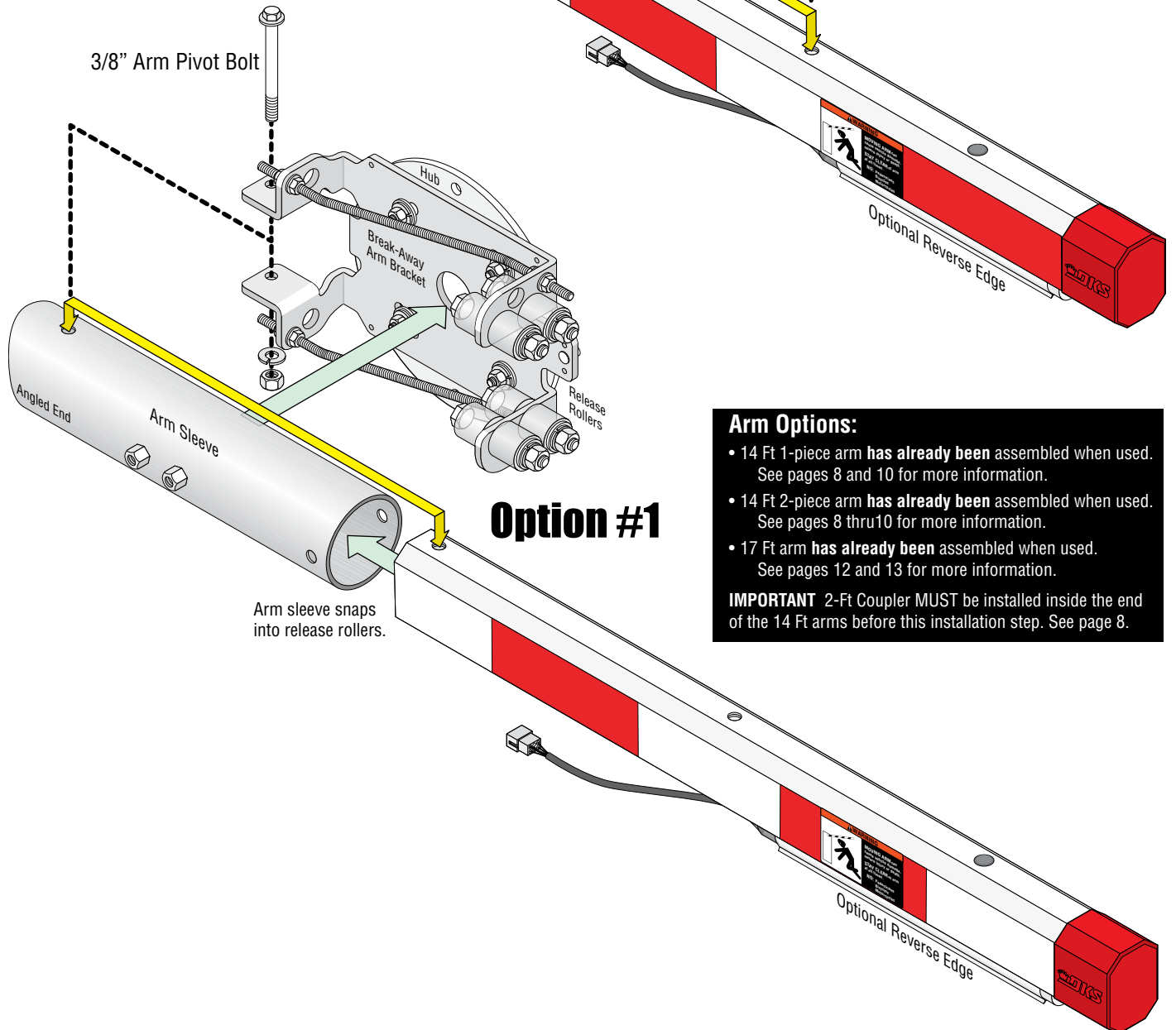

Arm Options:

- 14 Ft 1-piece arm **has already been** assembled when used. See pages 8 and 10 for more information.
- 14 Ft 2-piece arm **has already been** assembled when used. See pages 8 thru 10 for more information.
- 17 Ft arm **has already been** assembled when used. See pages 12 and 13 for more information.

IMPORTANT 2-Ft Coupler **MUST** be installed inside the end of the 14 Ft arms before this installation step. See page 8.

6 Mount Power Supply and Relay

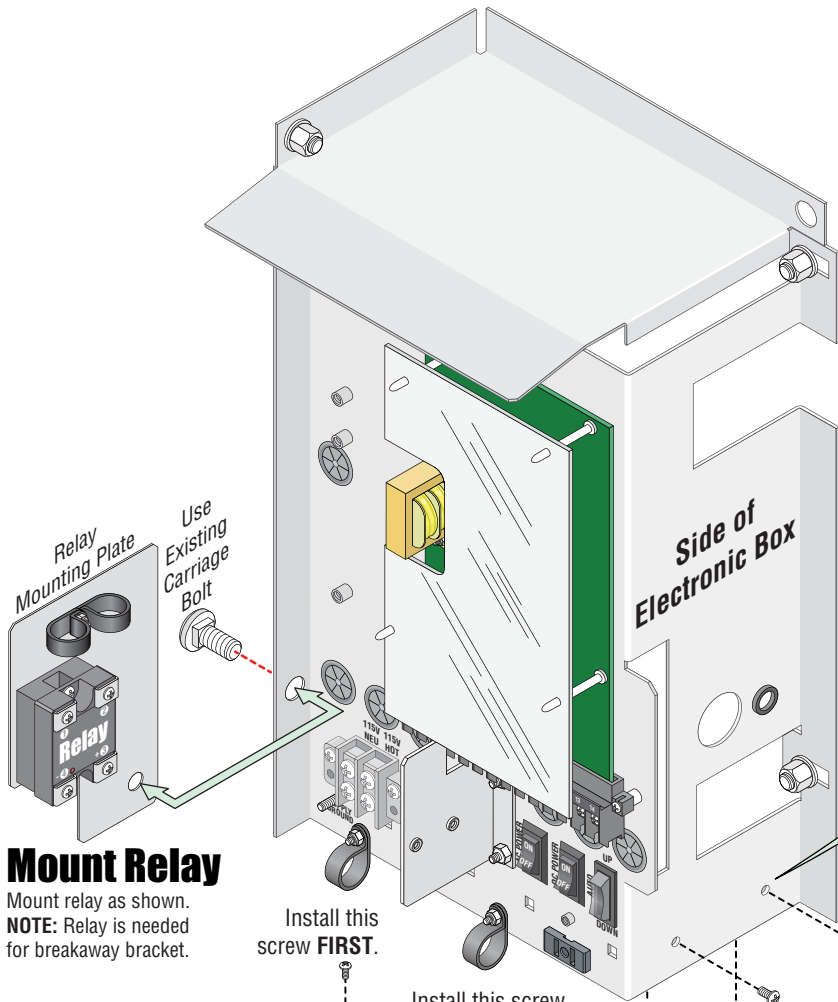

Mount Relay

Mount relay as shown.
NOTE: Relay is needed for breakaway bracket.

Install this screw **FIRST**.

Install this screw **SECOND**.

Mount Power Supply

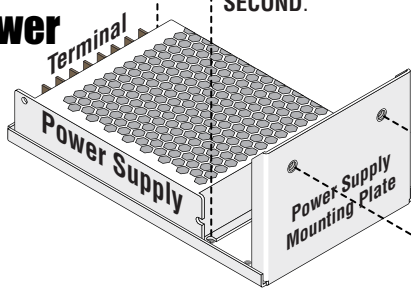

IMPORTANT: Power supply **MUST** be wired **BEFORE** mounting the power supply mounting plate as shown. See next page.

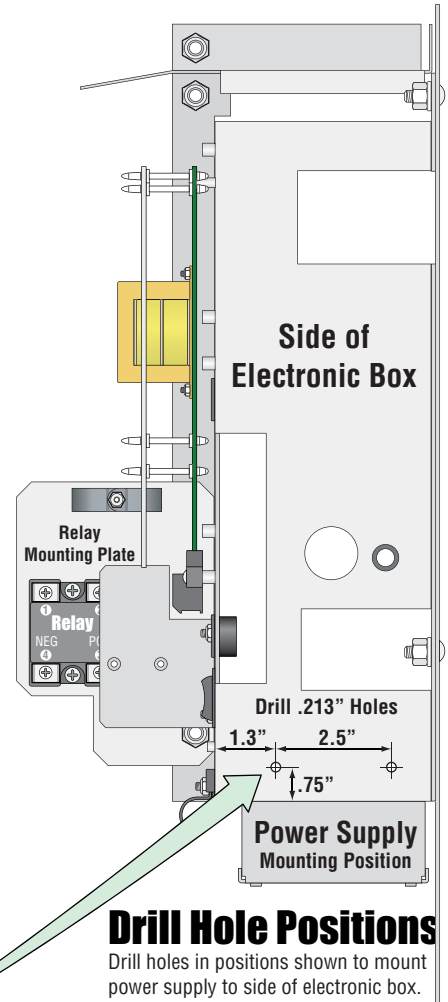

Drill Hole Positions

Drill holes in positions shown to mount power supply to side of electronic box.

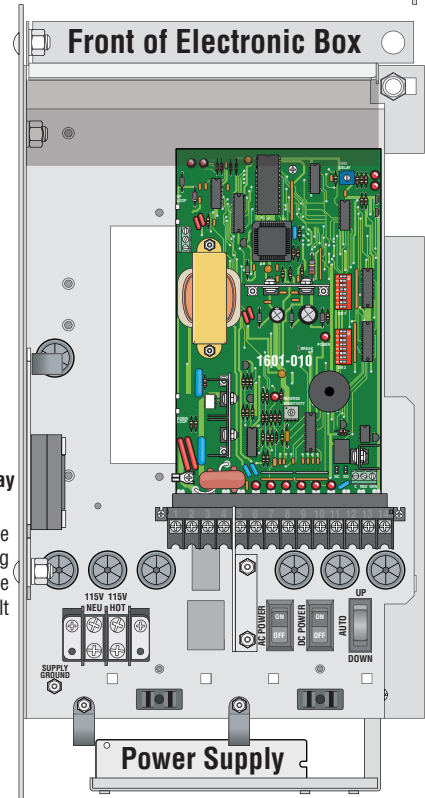

7 Octagon Break-Away Arm - Wiring to Operator

MAKE SURE ALL POWER IS TURNED OFF TO OPERATOR!

OPTIONAL Convenience Open 1473

NOTE: Break-Away arm Will NOT work with older model 2340-010 convenience open board.

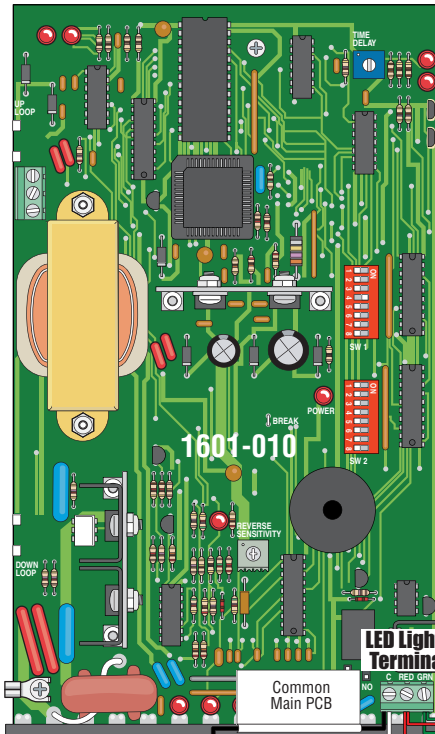
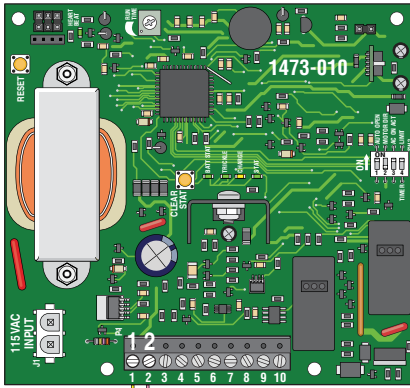

Optional LED Traffic Light Kit Sold Separately

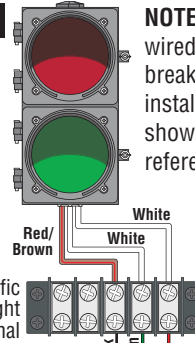

NOTE: The traffic light is wired together with the break-away arm in some installations, so it's shown here for wiring reference. See Traffic Light manual 1603-264 for more info when used.

Make sure ANY unused wires are properly terminated and do NOT have exposed bare wires or metal connectors that could cause the operator to malfunction.

SUPPLY GROUND
Green Ground Panel Stud L24 Required

Remove EXISTING wire from Main PCB Terminal 2 and connect it to Relay #1
Relay for Breakaway Sensors

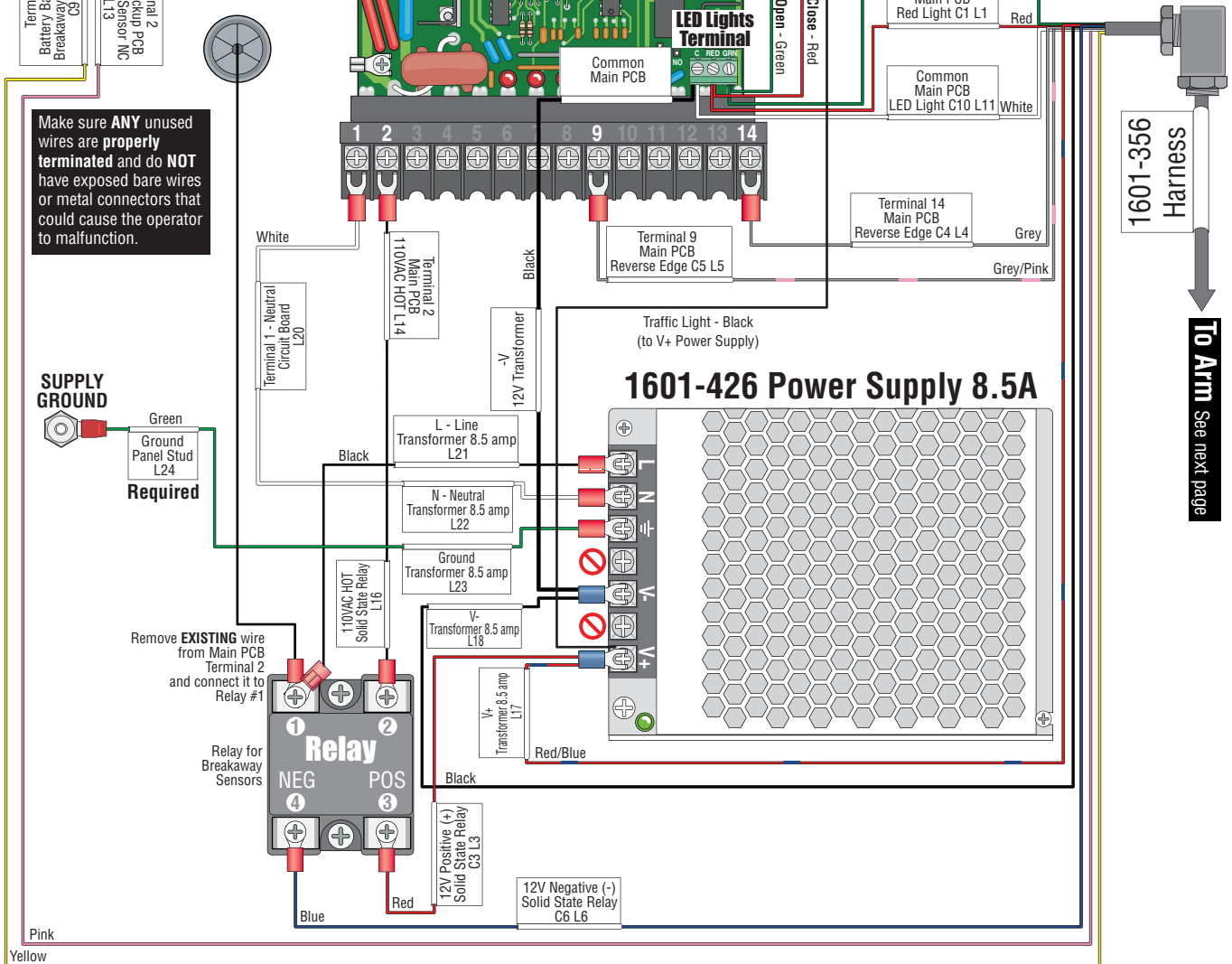

1601-356 Harness
To Arm See next page

8 Connect Arm to Wire Harness (1601-356)

MAKE SURE ALL POWER IS TURNED OFF TO OPERATOR!

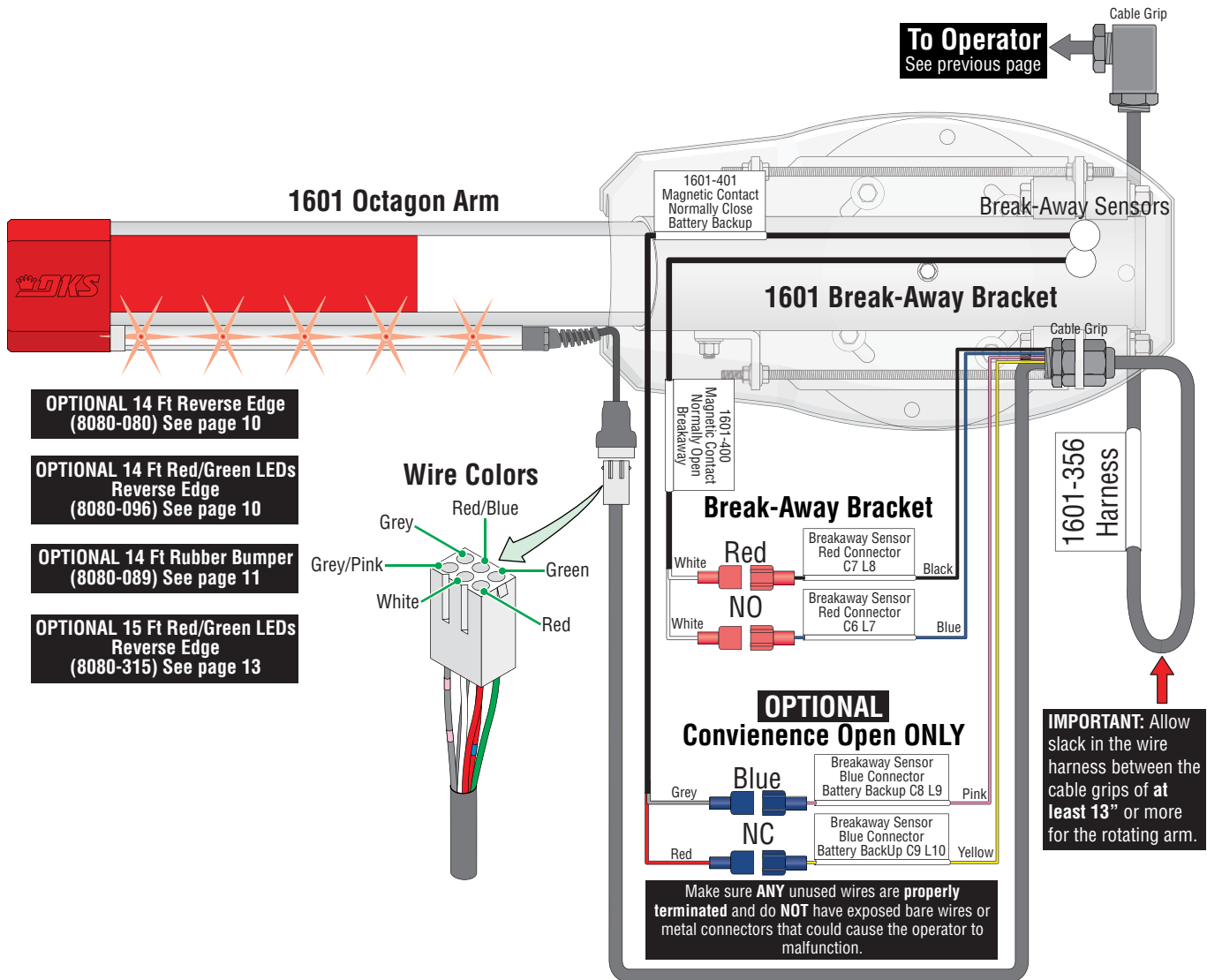

9 Secure Wires to Break-Away Bracket Option #1

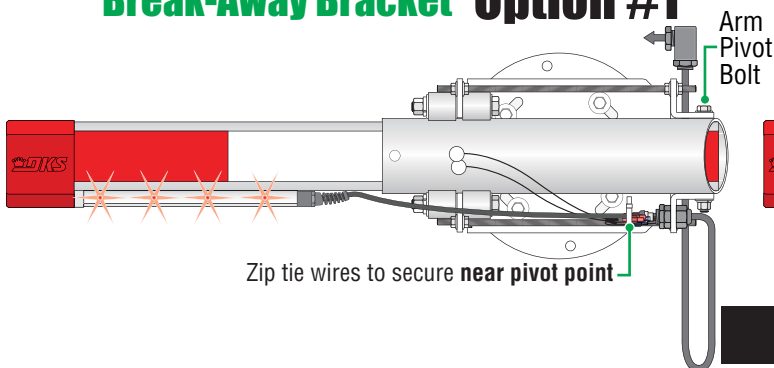

Option #2

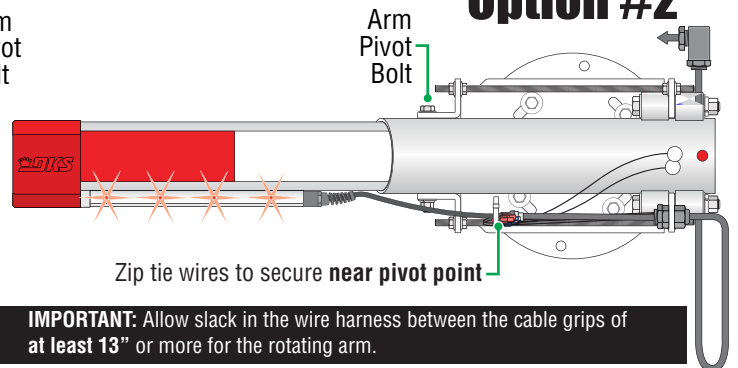

10 Break-Away Arm Reset Procedure

If arm gets struck and breaks away, gate operator will automatically shut down (Break-away sensors are tripped). Simply snap arm back into the release rollers. Make sure all wires are out of the way of the arm when snapping arm back in position. Normal operation can then continue.

DO NOT OPERATE ARM WITHOUT BREAK-AWAY SENSORS FUNCTIONING.

2 Ft Coupler Installation (Required)

2 Ft Coupler is included in the kit and **MUST** be installed on your chosen arm to add stiffness when arm is cycling.

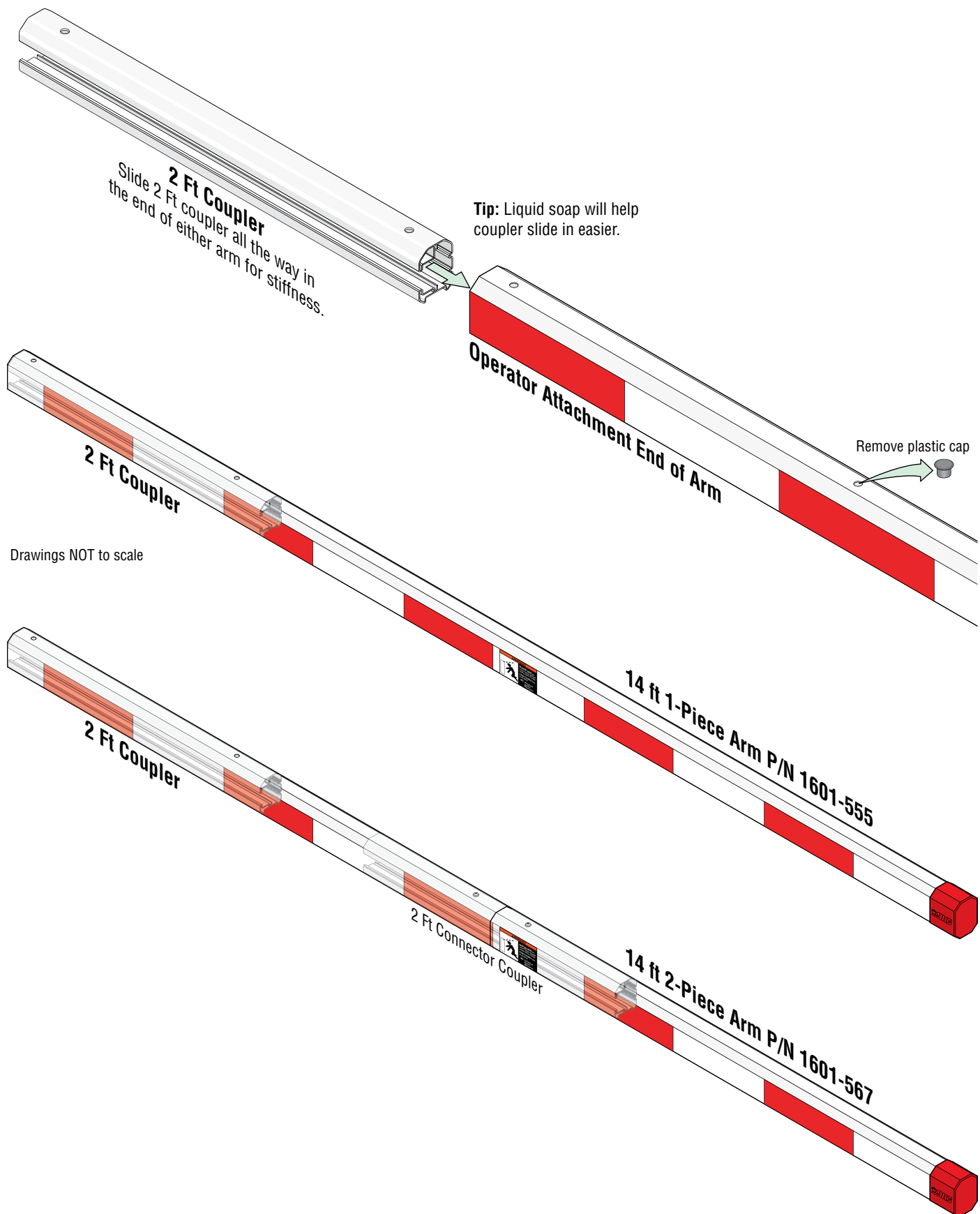

Drawings NOT to scale

14 Ft 2-Piece Octagon Arm Assembly

DoorKing Part Number

1601-567

14 Ft 2-Piece Octagon Arm Kit

This kit is designed for use on a 1601 barrier gate operator **ONLY**. It has 2-7 ft arm sections that assemble into a 14 ft arm.

A reverse edge can be installed on this arm. It is sold separately but **highly recommended** for safety, see next page.

Assemble 2-Piece Arm

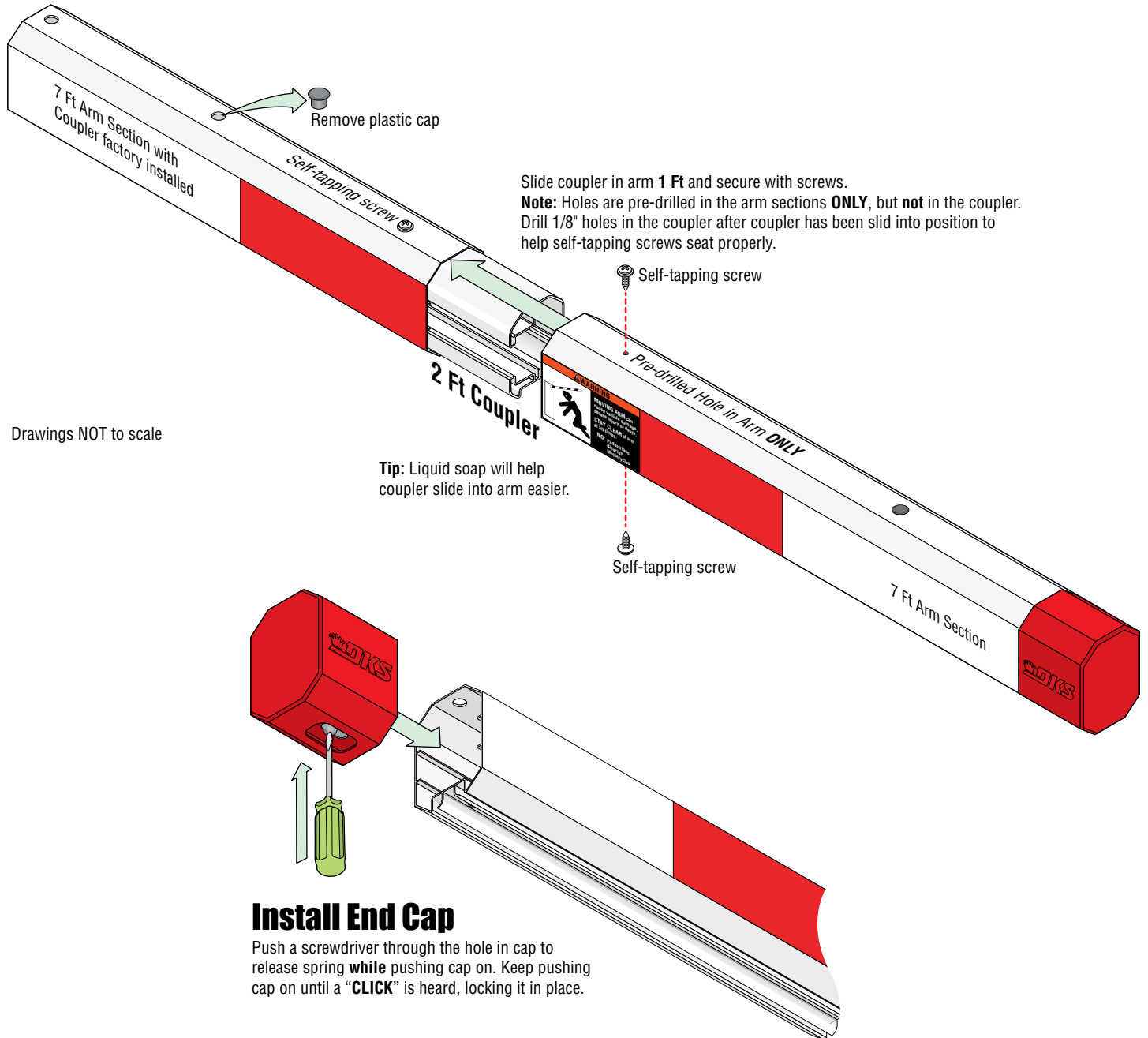

14 Ft Reverse Edge / Red Green LED Installation

DoorKing Part Numbers

8080-080

14 Ft Reverse Edge

8080-096

14 Ft Reverse Edge + Red/Green LED

This kit is designed to install on a 14 ft 1-piece or 2-piece **octagon arm** for a 1601 barrier gate operator. It **CANNOT** be used with a 1602 or 1603 operators.

Note: DO NOT operate arm with a malfunctioning reverse edge.

Installation

Drawings NOT to scale

2 Slide on Stopper

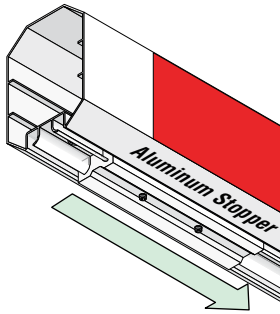

3 Slide on Edge

Tip: Liquid soap will help reverse edge slide on easier.

4 Reinstall End Cap

Push a screwdriver through the hole in cap to release spring while pushing cap on. Keep pushing cap on until a "CLICK" is heard which locks it in place.

1 Remove End Cap

Push a screwdriver through hole in bottom of end cap to release spring while pulling cap off.

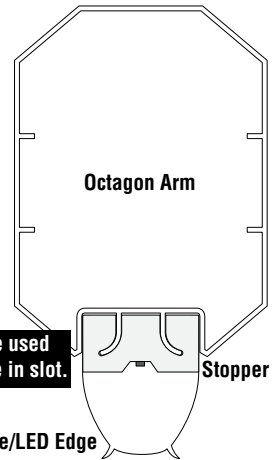

Stopper MUST be used or edge will slide in slot.

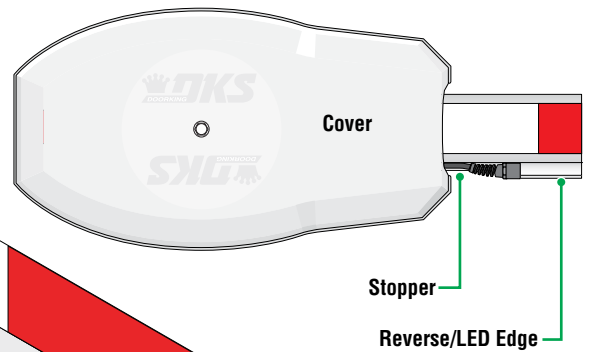

Tighten set screws.

Stopper MUST be used or edge will slide in slot.

14 Ft Rubber Bumper Installation

DoorKing Part Number
8080-089
14 Ft Rubber Bumper

This rubber bumper is designed to install on a 14 ft 1-piece or 2-piece **octagon arm** (not included) for a 1601 barrier gate operator.
It **CANNOT** be used with a 1602 or 1603 operators.

Installation

Drawings NOT to scale

1 Remove End Cap

Push a screwdriver through hole in bottom of end cap to release spring **while** pulling cap off.

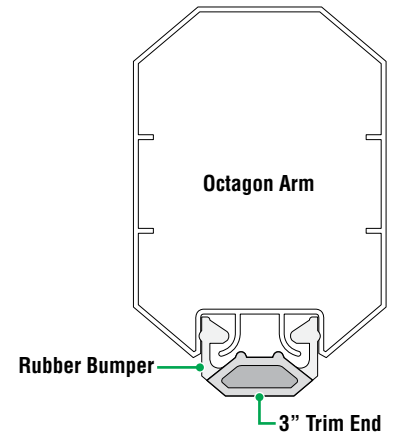
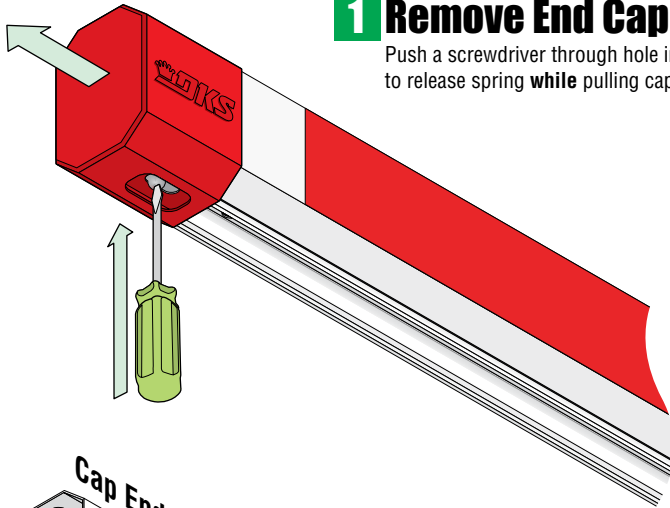

2 Slide on Rubber Bumper

The 3" trim end **MUST** side on first and it fits into the cover, see cover illustration.

Tip: Liquid soap will help rubber bumper slide on easier.

3 Reinstall End Cap

Push a screwdriver through the hole in cap to release spring **while** pushing cap on. Keep pushing cap on until a "**CLICK**" is heard which locks it in place.

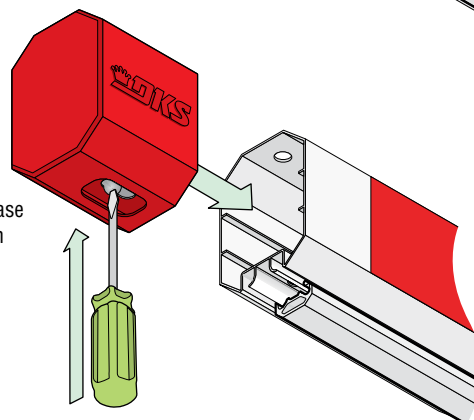

3" trim end **MUST** be on the operator end as shown.

17 Ft Octagon Arm Assembly for a 1602 ONLY

DoorKing Part Numbers:

1602-303

Octagon Arm 3-ft Extension Kit

8080-315

15-ft Reverse Edge + Red/Green LED

(Sold Separately)

See next page)

This kit is designed for a **1602** barrier gate operator **ONLY**. It **CANNOT** be used with 1601 barrier OR 1603 auto-spikes barrier operators. It will extend a 14 ft octagonal arm an **extra three feet**. The reverse edge is sold separately but **highly recommended** for safety when lowering this very long arm.

Installation

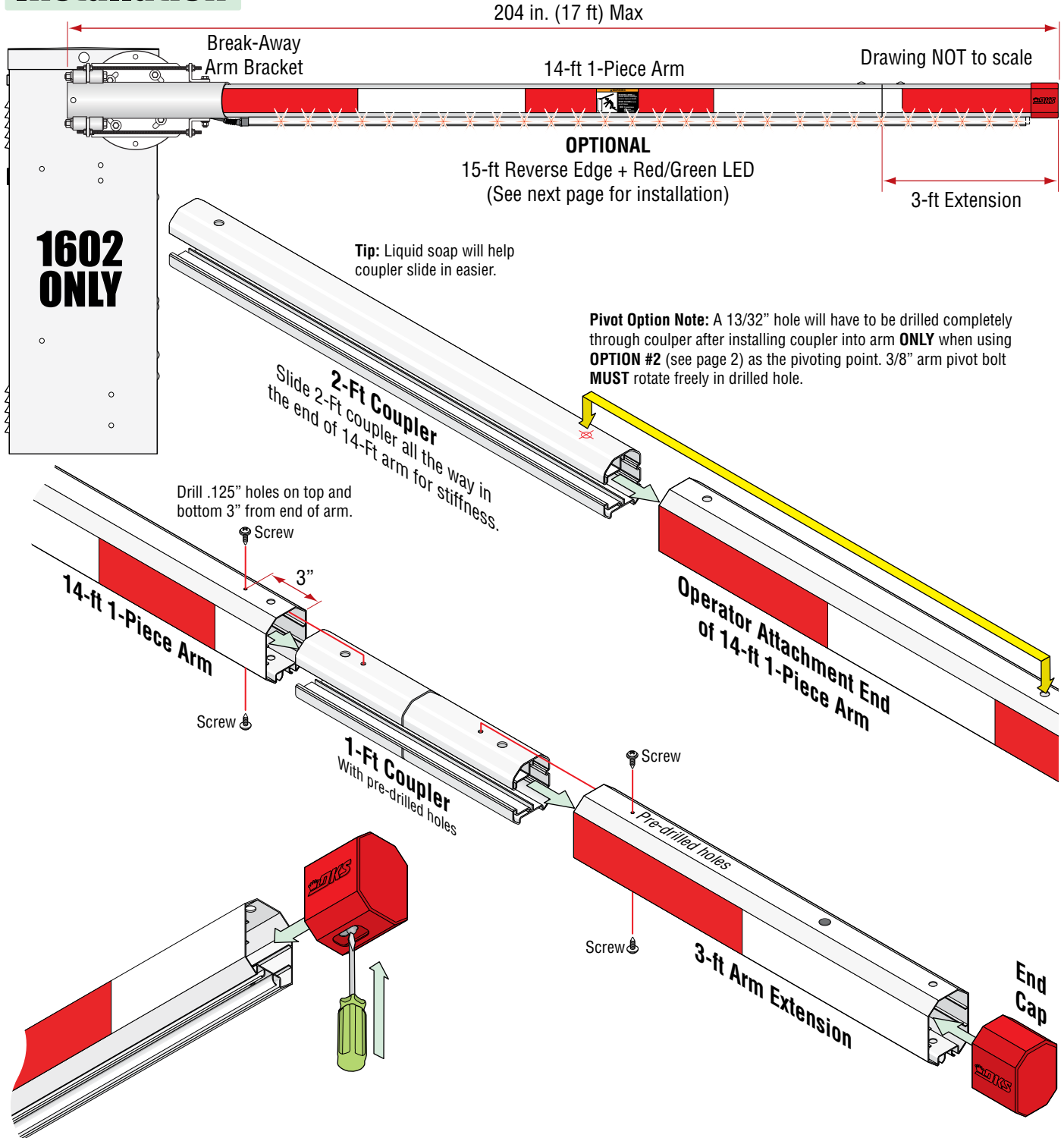

Install End Cap

Push a screwdriver through the hole in cap to release spring **while** pushing cap on. Keep pushing cap on until a "**CLICK**" is heard, locking it in place.

1601-269-R-10-24

15 Ft Reverse Edge / Red Green LED Installation on 17 Ft Arm ONLY

DoorKing Part Number:

8080-315

15-ft Reverse Edge + Red/Green LED
(Sold Separately)

This edge will **ONLY** fit on a 14-ft octagon arm with the **3-ft extension** installed on it.

Note: DO NOT operate arm with a malfunctioning reverse edge.

Installation

Drawings NOT to scale

2 Slide on Stopper

Loosen set screws.

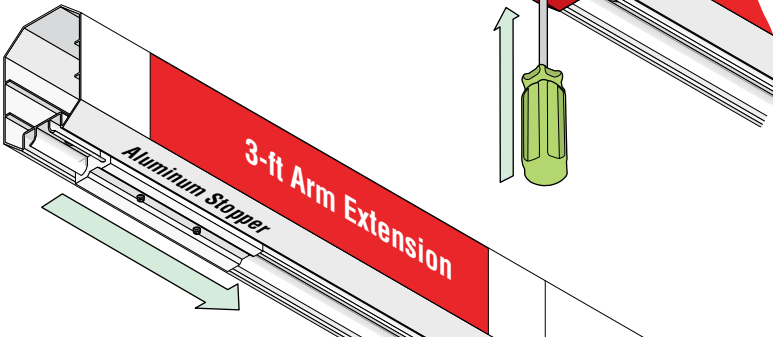

1 Remove End Cap

Push a screwdriver through hole in bottom of end cap to release spring **while** pulling cap off.

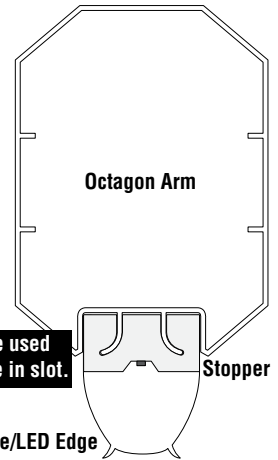

Stopper MUST be used or edge will slide in slot.

Reverse/LED Edge

Reverse/LED Edge

Cover

Push stopper against reverse edge and tighten it so edge does **NOT** slide in slot.

3 Slide on Edge

Tip: Liquid soap will help reverse edge slide on easier.

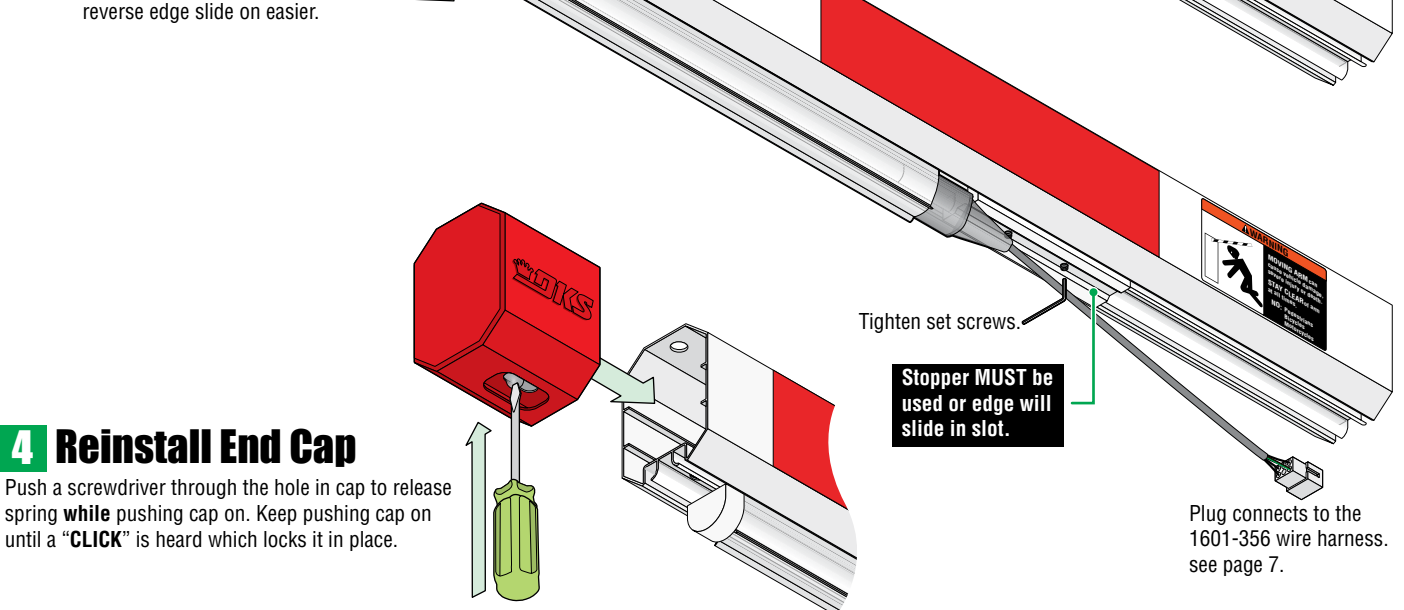

Tighten set screws.

Stopper MUST be used or edge will slide in slot.

Plug connects to the 1601-356 wire harness. see page 7.

Older Existing Arm Cover

Older existing plastic arm cover will need to have a notch cut out for the reverse edge. Only one side of the cover will need to be cut out depending on which side of the operator the arm is mounted on. Use this template as a guide to remove material from the cover.

