

REVISIONS			
REV.	DESCRIPTION	DATE	APPROVED
A	Production Release	07/30/18	PSK
B	Remove 6500-453 & 6500-453 Covers; Add 6500-454 & 6500-464 Covers	01/29/19	DC
C	Remove Panel 6500-232; Add 6500-243	05/04/20	Tpham
D	Update IPB completely: Removed drawing views of 6500-440 Cover, 6500-400 Hub Assy and 6500-430 Arm; Added 1702-505 1X; 2600-805 2X was 1X; 2600-810 1X was 7X; 2615-053 2X was 4X; Added 2615-055 4X; 2615-082 4X replaced 2615-081 4X; Added 2616-002 4X; Removed 2616-018 4X; 2616-062 2X replaced 2616-060 2X; 2620-019 4X was 8X; 2620-047 6X was 4X; 2620-076 2X replaced 2620-075 3X; 2620-409 2X was 6X; 2620-411 9X was 8X; Added 2902-010 1X; Added 4001-055 1X; 6500-118 1X replaced 6500-148 1X; Removed 6500-123 1X; Added 6500-381IPB; Removed 6500-881IPB; 6600-035 2X replaced 6600-030&6600-032;	10/22/20	Tpham

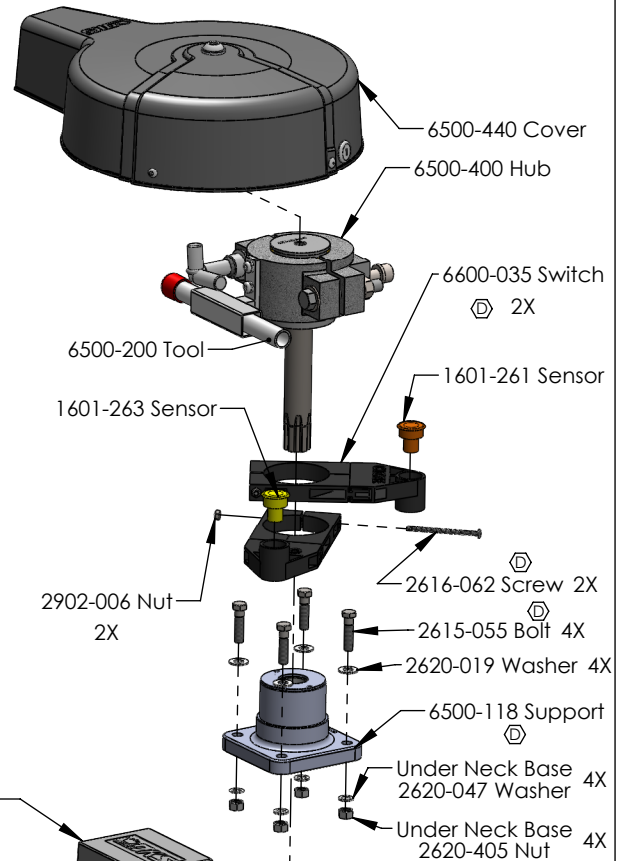

Front View IPB

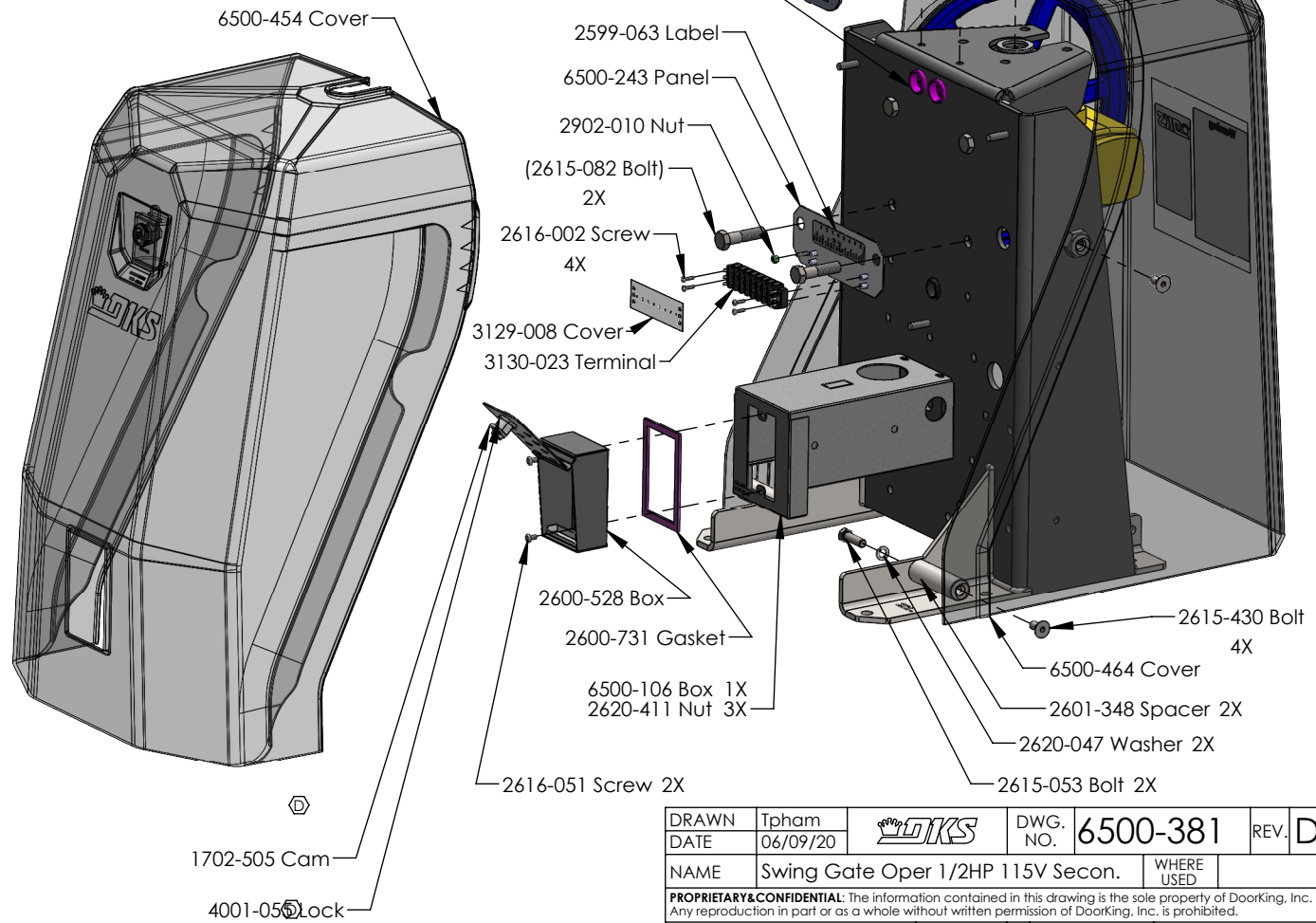

DRAWN	Tpham		DWG. NO.	6500-381	REV.	D
DATE	06/09/20		SHEET NO.	1		
NAME	Swing Gate Oper 1/2HP 115V Secon.		WHERE USED			
<small>PROPRIETARY & CONFIDENTIAL: The information contained in this drawing is the sole property of DoorKing, Inc. Any reproduction in part or as a whole without written permission of DoorKing, Inc. is prohibited.</small>						
DO NOT SCALE TO DRAWING			SHEET SIZE	A	SCALE:	1:50
				SHEET 1 OF 3		

Back View IPB

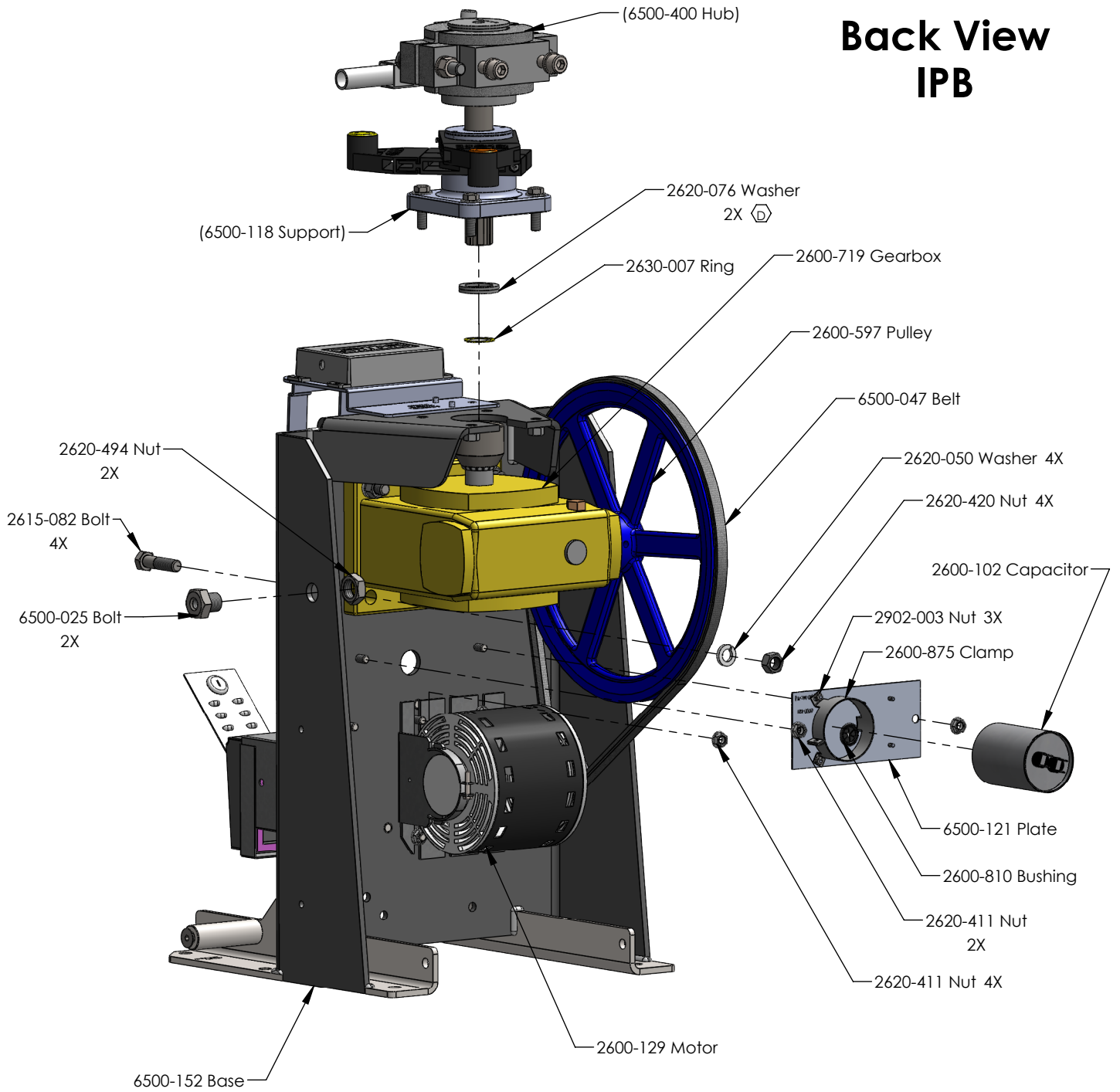

DRAWN	Tpham		DWG. NO.	6500-381	REV.	D
DATE	06/09/20		WHERE USED			
NAME	Swing Gate Oper 1/2HP 115V Secon.					
PROPRIETARY & CONFIDENTIAL: The information contained in this drawing is the sole property of DoorKing, Inc. Any reproduction in part or as a whole without written permission of DoorKing, Inc. is prohibited.						
DO NOT SCALE TO DRAWING		SHEET SIZE	A	SCALE: 1:50	SHEET 2 OF 3	

PartNo	Description	QTY.
1601-261	Switch Mag Sensor Rec Orange	1
1601-263	Switch Mag Sensor Reces Yellow	1
1702-505	Cam 9/16"	1
2599-063	Label 6500 8 Terminal Master-Slave	1
2599-100	Sign Warning Gate (not shown on drawing)	2
2599-220	Label Caution Remove Rod (not shown on drawing)	1
2600-102	Capacitor 50uf 370VAC	1
2600-129	Motor Assy 1/2HP 6100-9100	1
2600-528	Switches and Alarm Box	1
2600-597	Pulley-13" Cast Iron AK130x7/8	1
2600-719	Gearbox Swing Gate 6500 Spline	1
2600-731	Gasket Switch Cover	1
2600-757	Wire 9 Conductor Cable 50FT (not shown on drawing)	1
2600-805	Bushing 1 3/32 Poke Thru Flaps	2
2600-810	Bushing 7/8 Poke Thru Flaps	1
2600-875	Capacitor Mounting Clamp	1
2601-348	Spacer Cover Left Model 9000	2
2615-053	Bolt Hex 3-8-16X1 1-4	2
2615-055	Bolt Hex Head 3/8-16x1.5	4
2615-082	Bolt Hex Head 1/2-13x2	4
2615-430	Bolt Flat Hd Hex 3/8-16x3/4 SS	4
2616-002	Screw Phillips Head 6-32x1/2	4
2616-051	Screw Phillips 10-32x3/8	2
2616-062	Screw Phillips Head 10-32 x 3.0 Zinc	2
2616-097	Set Screw 5/16-18x3/8 (not shown on drawing)	1
2620-019	Washer 3-8 ID SAE	4
2620-047	Lockwasher 3/8-16	6
2620-050	Lockwasher 1/2"	4
2620-076	Washer 1.125IDx1.63ODx.125T	2
2620-405	Nut 3/8-16	4
2620-409	Nut Hex Flange Lock 1/4-20	2
2620-411	Nut Hex Flange Lock 5/16-18	9
2620-420	Nut Hex 1/2-13	4
2620-494	Nut Jamb 3/4-16	2
2630-007	Snap Ring 1.125" ID	1
2700-104	Box 23.25"x19"x34" (not shown on drawing)	1
2700-119	Box 11.125"x9"x2.5" (not shown on drawing)	1
2700-401	Pallet 23"x28.75"x14" (not shown on drawing)	1
2902-003	Nut Nylon Locking 6-32	3
2902-006	Nut Nylon Locking 10-32	2
2902-010	Nut Nylon Locking 8-32	1
3129-008	Terminal Block Cover 8 Position	1
3130-023	Terminal Strip 8 Dual Row Screw	1
4001-055	Lock Cabinet 10025 180deg 16001	1
6500-025	Bolt Center Tapped	2
6500-045	Wire Set Slave 6500 Operator (not shown on drawing)	1
6500-047	Belt 47in for 17in Pulley 4L470	1
6500-106	Switch Box Bracket	1
6500-118	Shaft Support Assembly	1
6500-121	Capacitor Plate	1
6500-152	Base Stand Swinger 6500	1
6500-200	Tool-Hub Clutch Release	1
6500-243	Panel Secondary	1
6500-307	Cover Lock Panel	1
6500-381IPB	IPB Swing Gate Oper 1/2HP Secondary	1
6500-400	Hub Assembly 1/2HP	1
6500-430	Arm Main Assembly (not shown on drawing)	1
6500-440	Cover Turet Assembly	1
6500-454	Cover Front Slip and Lock	1
6500-464	Cover Back with Labels	1
6600-035	Limit Switch Single Sensor	2
9402-053	Tubing Flex/Split 1/4 OD-2in (not shown on drawing)	1
9402-055	Tubing Flex Split 1/2" OD-0.2FT (not shown on drawing)	1

DRAWN	Tpham		DWG. NO.	6500-381	REV.	D
DATE	06/09/20		NAME	Swing Gate Oper 1/2HP 115V Secon.	WHERE USED	
PROPRIETARY & CONFIDENTIAL: The information contained in this drawing is the sole property of DoorKing, Inc. Any reproduction in part or as a whole without written permission of DoorKing, Inc. is prohibited.						
DO NOT SCALE TO DRAWING			SHEET SIZE	A	SCALE: 1:50	SHEET 3 OF 3