



2112 eVolve

VIDEO ENTRY SYSTEM



Flush Mount

Surface Mount

Surface Mount Curved



Internet Connection - Wired or Wireless

Voice or Video calling and access management from anywhere with the DKS Cloud

- The 2112 eVolve is our most advanced and versatile Video Entry System, allowing the homeowner or system users the ability to grant entry to guests even from thousands of miles away.
- The 2112 features Video or Voice calls in a broadcast mode for up to 4 phones simultaneously when the call button is pushed.
- The 2112 control dashboard is browser based, so all that's needed is an internet connection and a web browser to access Entry System settings such as users, access time zones, entry codes and more.
- Residents can quickly grant guests access from their home phone or smartphone.
- Able to control up to three entry points, the 2112 eVolve operates with an internet connection or an optional cellular connection.



NEW eVolve Technology Inside



Internet or Cellular Connection

Use your existing internet connection or optional cellular connection for easy Plug & Play connectivity



Upgraded Camera

With a powerful camera and enhanced ISO sensitivity, you'll get a crystal-clear, detailed image day or night.



Live Video Streaming

Users with the DKS video calling app downloaded to their smartphone are able to communicate with guests via video stream



Voice Communication

Talk to guests at a front door or gate from any telephone in the home, or mobile phone



Broadcast Calling

Access requests from the call button can ring up to 4 phones simultaneously.



Control from Any Device, Anywhere

Administrators can access system settings from any browser via the cloud.

ACCESS CONTROL SOLUTIONS

DKS DOOR KING **2112 eVolve**
VIDEO ENTRY SYSTEM

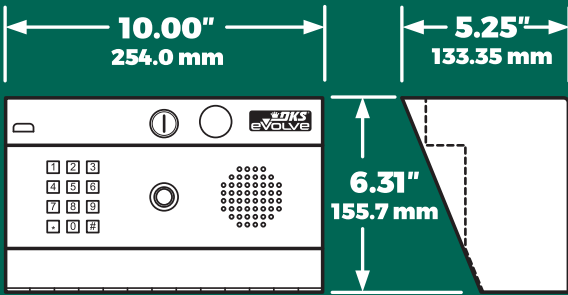

2112 Surface Mount

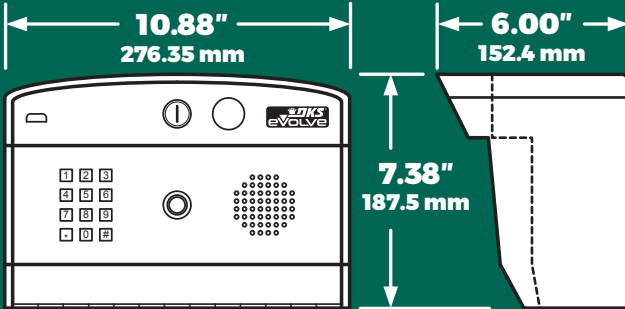

2112 Surface Mount Curved

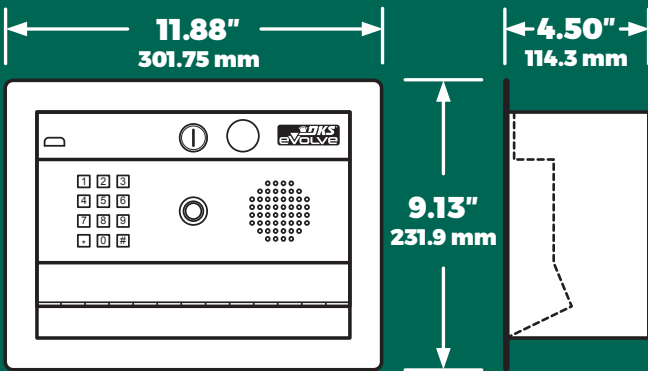

2112 Flush Mount

MODEL	2112
PHONE NUMBERS	10 Residents, four (4) phone numbers per resident
ENTRY CODES ¹	Programmable (500 max) can be set to four (4) or five (5) digits
RELAYS	Three (3) Type C

1. Entry codes grant access when entered on the system keypad

TECHNICAL FEATURES

PROGRAMMING/USER FEATURES

Programming via Internet Browser using a laptop, tablet or smartphone
DKS Video Calling app

All programming is shared in the cloud, updates show as they occur

CONNECTIVITY NETWORK CONNECTION

User provided Internet connection required
Standard Residential Package Registration is required

CONNECTIVITY CELLULAR CONNECTION

Cellular connection available if Internet connection is not possible. Additional cellular connection fee applies.

FEATURES

- Cloud based system
- standard monthly fee applies to use the 2112
- User provided Internet connection standard
- Up to 10 residents with a maximum of four (4) phone numbers per resident
- Entry codes (500 max) can be set to four (4) or five (5) digits
- Built-in IP Camera for Video Calling
- Broadcast Calling (up to four numbers simultaneously)
- Do Not Call schedule
- Hold Open schedule
- Entry Code schedule
- Microphone / Speaker volume control
- Relay Status
- Relay (Entry Point) names
- Independent relay strike times
- Relay (Door/Gate) control

ELECTRICAL/MECHANICAL

- 16 VAC or 12-24 VDC Power Input
- 16VAC, 20 VA transformer provided
- Three (3) type C relays, 1A max
- Back Lighted Metal Keypad
- Back Lighted Metal Push to Call button
- Stainless Steel Faceplate
- Galvanized Steel sub plate

MISCELLANEOUS

Environmental: 10°F to 145°F (-12°C to 62°C)
Shipping weight approximately 15 lb (7 kg)

FCC (US) DUF6VT-12874-OT-T
DOC (CAN) 1736 4528 A

DoorKing®, Inc.

Access Control Solutions since 1948



120 S. Glasgow Avenue,
Inglewood, California 90301 U.S.A.
Tel: 310-645-0023 FAX: 310-641-1586
www.doorking.com

© 2025 All Rights Reserved.
Product specifications may change without notice. Rev. 3/25



MEMBER:



DISTRIBUTED BY:

