

REVISIONS

REV.	DESCRIPTION	DATE	APPROVED
A	Created 1603-381 from 1603-181	6/9/2021	DC

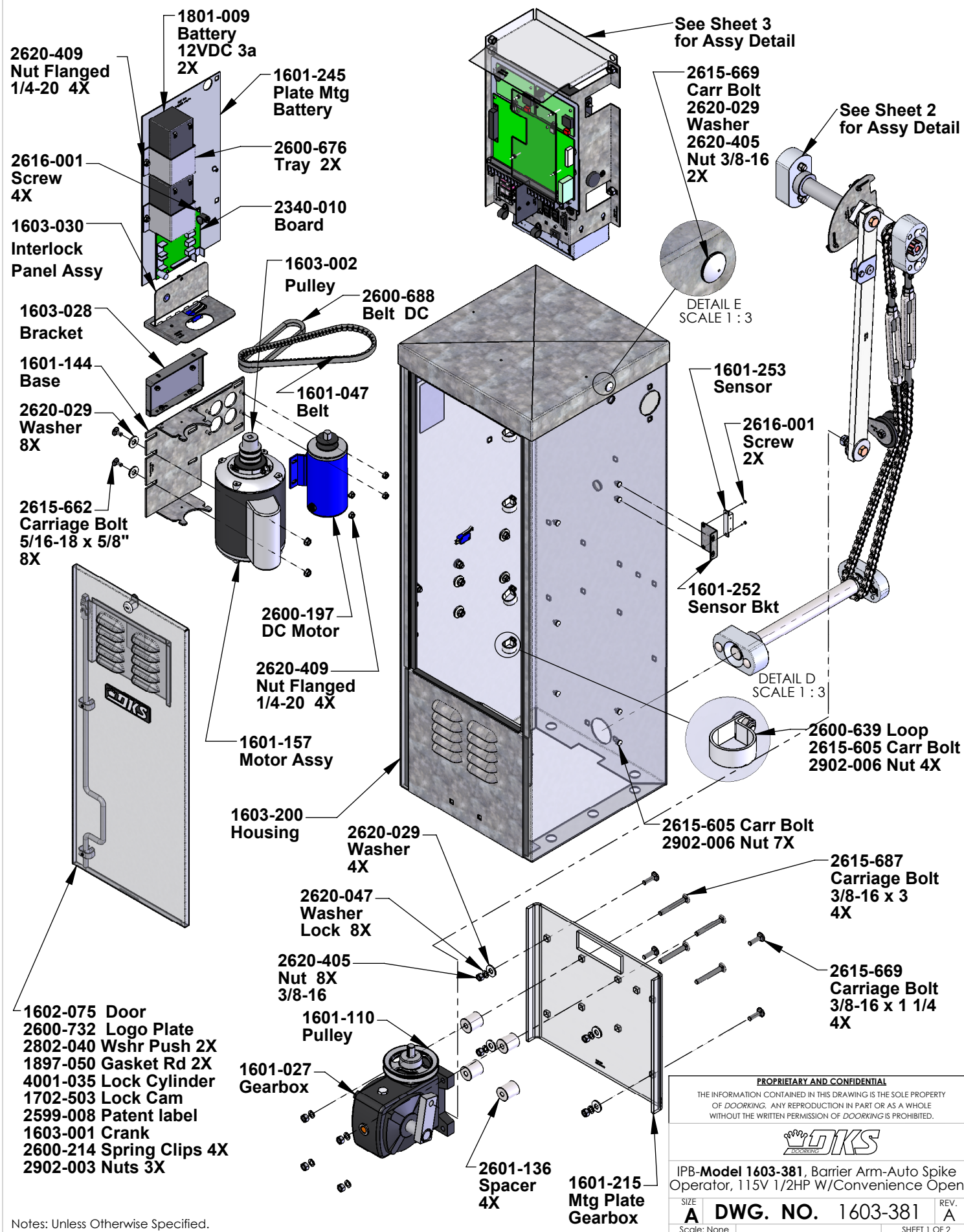

Notes: Unless Otherwise Specified.

PROPRIETARY AND CONFIDENTIAL

THE INFORMATION CONTAINED IN THIS DRAWING IS THE SOLE PROPERTY OF DOORKING. ANY REPRODUCTION IN PART OR AS A WHOLE WITHOUT THE WRITTEN PERMISSION OF DOORKING IS PROHIBITED.

IPB-Model 1603-381, Barrier Arm-Auto Spike Operator, 115V 1/2HP W/Convenience Open

SIZE	DWG. NO. 1603-381	REV. A
Scale: None	SHEET 1 OF 2	

