



Section C1

This Price Schedule is effective March 4, 2024.

Maximum Security Operators & Barriers

Date	Page	Comment
3-4-24	All	March 2024 Price Schedule update.
3-20-24	7	Clarified options for 95x0 and 95x5 operators.
5-22-24	6, 7	Added single-phase power options.
5-23-24	7	Added additional notes to clarify single-phase transformer requirements.
6-24-24	2, 8	Editorial corrections.
6-28-24	12, 13	Added 16 Ft. and 18 Ft. wedges.

Maximum Security Gate Operators

9500 series operators are designed to operate very large vehicular gates used in Limited (Class III) and Restricted (Class IV) maximum security applications only. These operators must never be used in Residential (Class I) or Commercial (Class II) applications, or in any application where the gate is operated by the General Public.

These operators must be installed with external entrapment prevention devices, Type B1 (non-contact) or Type B2 (contact), or a combination of both to insure all entrapment hazard areas are protected. **9500 Series operators require a minimum of one (1) Type B1 AND one (1) Type B2 in EACH direction of travel.** Refer to the Installation Manual for important safety information.

Minimum Gate Length

The 9500 Series operators have variable speed capability which allows the user to adjust the speed of the gate. On most operators, the speed can be set for speeds up to 2 Ft/sec., and on certain models the gate speed can be set up to 4 Ft/sec. When using these higher speeds, there is a time factor to consider during the start-up and the slow-down of the gate. For this reason, you will see a minimum gate length on operators design to move a gate at higher speeds.

1620 Series Lane Barriers

1620 Lane Barriers are NOT crash rated. They are intended to provide a formidable barrier to help prevent passenger cars and light-duty pickup trucks from breaching a parking arm operator system. These barriers are not a stand-alone product, they are designed to be mechanically linked to a 1603-580 lane barrier operator.

1625 Series Wedge Barriers

1625 Wedge Barriers are crash rated to the ASTM F2656-20 standard. Wedge barriers are intended to provide a formidable barrier to help prevent passenger cars and light-duty pickup trucks (up to 5,070 Lbs) from breaching a standard parking arm operator system. These barriers are not a stand-alone product, they are designed to be mechanically linked to a 1602-590 operator.

UL 325 – February 2023

Requirements mandated by the safety standard (UL 325) that DKS gate operators are listed to require that photo-beams and contact edges used for entrapment protection must be monitored. Entrapment protection must be provided for the gate system where the risk of entrapment exist. The gate operator will not run without one or more external entrapment protection devices installed in each direction of travel. Check the gate operator installation manual for a list of external entrapment protection devices that can be used with DKS gate operator products.

The August, 2018 update to the safety standard requires that a minimum of two independent means of entrapment protection must be provided, in each direction of travel, where the risk of entrapment exists. The actual number of external devices required is dependent on the gate system layout and the number of entrapment areas that will need to be protected. Installers will have to identify all potential areas where the risk of entrapment exist and how best to protect those areas. For example, some gates may require two (or more) external devices in each direction of travel to protect all potential areas of entrapment. **9500 Series operators require a minimum of one (1) Type B1 AND one (1) Type B2 in EACH direction of travel.**

There is an exception for swing gates and vertical lift gates regarding the minimum of two entrapment protection devices in each direction of travel. For example, if on a swing gate system there is no potential for entrapment in the opening direction, then only the close direction will require a minimum of two means of entrapment protection. Installers will have to determine if any entrapment hazards exist in the opening direction, and if so, then those areas will have to be protected with external devices.

Vertical lift gates require two means of entrapment protection in the down cycle, but will only require one means of entrapment protection in the up cycle. The model 1175 is considered to be a vertical lift gate operator for entrapment protection means requirements.

Barrier gate operators that are installed in such a way that the barrier arm does not come closer than 16 inches to a rigid object are not required to protect against entrapment.

The table below shows the minimum entrapment protection requirements for each type of gate operator in the scope of the UL 325 Standard for Safety.

	Opening	Closing
Horizontal Slide Gate	2	2
Horizontal Swing Gate	2*	2*
Vertical Pivot Gate	2	2
Vertical Lift gate	1	2
Horizontal Bifold Gate	2	2

* For a horizontal swing gate operator, at least two independent entrapment protection means are required in each direction of travel. Except, if there is no entrapment zone in one direction of travel, only one means of entrapment protection is required in that direction of travel; however, the other direction must have two independent entrapment protection means.

Blank Page

Table of Contents

Heavy-Duty Maximum Security Slide Gate Operators	
9500 Series.....	6
Maximum Security Slide Gate Operator Accessories	
9500 Series.....	8
Heavy-Duty V-Wheel Assemblies.....	9
Lane Barriers	
1620 Series.....	10
Wedge Barriers	
1625 Series.....	12

9500 Series

Heavy-Duty Maximum Security Slide Gate Operators

- Plug-in Loop Detector Ports
- Built-in power and reset switches
- Two 115 VAC convenience outlets
- Partial open / anti-tailgate feature
- Variable Speed
- 20-Foot minimum gate width (6.1m)
- Gate tracker data output
- Selectable stop/ reverse function

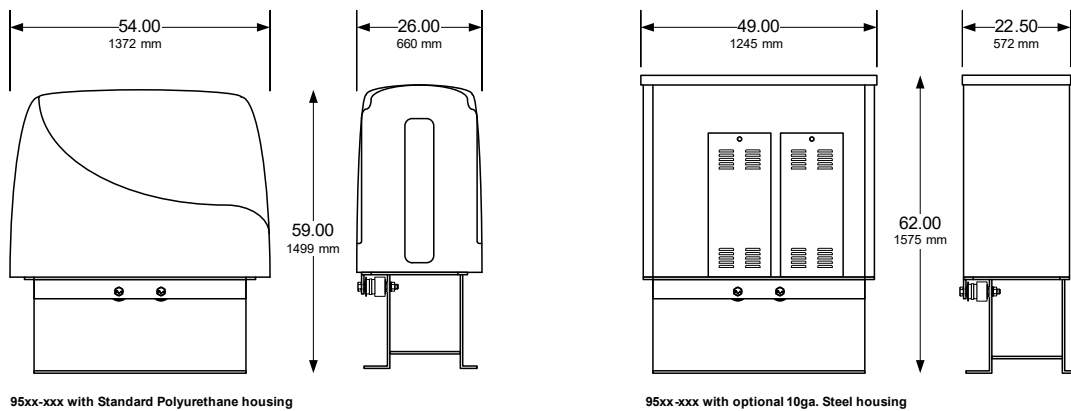

Model	Chain	Speed Variable	Maximum Gate Weight ¹	Maximum Gate Length	Minimum Gate Length	Class of Operation ²	Voltage VAC	HP	Gearbox Ratio	Magnetic Brake	Power Outlets	Loop Ports ³
9550	#100	1-2 Ft/sec .3-.6m/sec	15,000 (6803 Kg) Lb ⁴ 9,000 (4082 Kg) Lb ⁵	160 Ft 48m	20 Ft 6.1m	III, IV	208, 230, 460	5	30:1	Option	2	2
9555	#100	1-2 Ft/sec .3-.6m/sec	15,000 (6803 Kg) Lb ⁴ 9,000 (4082 Kg) Lb ⁵	160 Ft 48m	20 Ft 6.1m	III, IV	208, 230, 460	5	10:1	Standard	2	2
9570	#100	1-2 Ft/sec .3-.6m/sec	25,000 (11,339 Kg) Lb ⁴ 15,000 (6803 Kg) Lb ⁵	160 Ft 48m	20 Ft 6.1m	III, IV	208, 230, 460	7.5	30:1	Option	2	2
9575	#100	1-2 Ft/sec .3-.6m/sec	25,000 (11,339 Kg) Lb ⁴ 15,000 (6803 Kg) Lb ⁵	160 Ft 48m	20 Ft 6.1m	III, IV	208, 230, 460	7.5	10:1	Standard	2	2
9590	#100	1-2 Ft/sec .3-.6m/sec	28,000 (12,700 Kg) Lb ⁴ 16,800 (7620 Kg) Lb ⁵	160 Ft 48m	20 Ft 6.1m	III, IV	208, 230, 460	10	30:1	Option	2	2
9595	#100	1-2 Ft/sec .3-.6m/sec	28,000 (12,700 Kg) Lb ⁴ 16,800 (7620 Kg) Lb ⁵	160 Ft 48m	20 Ft 6.1m	III, IV	208, 230, 460	10	10:1	Standard	2	2

1. Assumes gate to be in good mechanical condition running on a level plane.
2. III = Limited Access; IV = Restricted Access.
3. Plug-in loop detector ports; open and reverse. DoorKing plug-in loop detectors only.
4. When using 3rd power.
5. When using 1st power.

All 9500 Series operators come standard with the polyurethane housing. The 10 Ga. steel housing is optional.

9500 Series

Heavy-Duty Maximum Security Slide Gate Operators

All orders for 9500 Series operators must be coordinated through the Regional Sales Manager. DoorKing order entry personnel will not enter the order into our manufacturing system until the RSM has approved the order. **Distributors must place orders through their RSM to confirm pricing.**

For any product that requires modification to meet project specifications, written instructions and specifications are required from the contractor before production begins.

Operators will not run without external entrapment protection devices connected to the controller board. Minimum of two (one in each direction of travel) is required. See installation manual for more information.

These operators are built to order and are not in finished goods inventory. Expect up to four weeks lead-time for delivery of these products. Operators come standard with the polyurethane housing. 10 Ga. steel housing is optional.

95x0 Standard Components

VF AC Drive Assembly - 30:1 Gearbox.

Specify 1^Ø or 3^Ø power. 3^Ø power requires 4001-101 transformer.

9550

9550-380 5 HP, 208V ²	31,026.00
9550-381 5 HP, 230V ²	31,026.00
9550-382 5 HP, 460V	31,026.00

9570

9570-380 7.5 HP, 208V ²	48,015.00
9570-381 7.5 HP, 230V ²	48,015.00
9570-382 7.5 HP, 460V	48,015.00

9590

9590-380 10 HP, 208V ²	52,632.00
9590-381 10 HP, 230V ²	52,632.00
9590-382 10 HP, 460V	52,632.00

Options 95x0 Operators Only

9550-206 Steel Housing w/Access Door ¹	6,909.00
4001-101 Transformer ²	2,739.00
2601-440 Magnetic Brake ³	4,282.50
2601-441 Magnetic Brake ⁴	4,320.00

1. Replaces the polyurethane housing with a 10 Ga. steel housing. Includes manual gate operation access door.
2. 4001-101 transformer is required if source power is 208 or 230 Volt single-phase.
3. Use with 7.5 and 10 HP units.
4. Use with 5 HP units.

95x5 Standard Components

VF AC Drive Assembly - Magnetic Brake - 10:1 Gearbox.

Specify 1^Ø or 3^Ø power. 3^Ø power requires 4001-101 transformer.

9555

9555-380 5 HP, 208V ²	36,120.00
9555-381 5 HP, 230V ²	36,120.00
9555-382 5 HP, 460V	36,120.00

9575

9575-380 7.5 HP, 208V ²	55,500.00
9575-381 7.5 HP, 230V ²	55,500.00
9575-382 7.5 HP, 460V	55,500.00

9595

9595-380 10 HP, 208V ²	56,310.00
9595-381 10 HP, 230V ²	56,310.00
9595-382 10 HP, 460V	56,310.00

Options 95x5 Operators Only

9550-205 Steel Housing ¹	6,789.00
4001-101 Transformer ²	2,739.00

1. Replaces the polyurethane housing with a 10 Ga. steel housing.
2. 4001-101 transformer is required if source power is 208 or 230 Volt single-phase.

9500 Series

Accessories

Chain

2601-272 #100 Chain, 20-Ft (6 m) 705.00

Accessories

2601-270 Chain Tray kit 10-Ft (3 m) Note 3

1601-197 Heater Kit 208/230 VAC¹ Note 2

1601-198 Heater Kit 480 VAC¹ Note 2

1. Use if temperature routinely falls below 10°F (-12°C).

2. See Section A1, page 41 for pricing.

3. See Section B1, page 9 for pricing.

Entrapment Protection (required) Devices

Use Type B1 (non-contact) and/or Type B2 (contact) entrapment protection devices to protect all areas where the risk of entrapment exist - see Section A1, pages 46-47.

Operator will not run without external entrapment protection devices connected to the controller board. Minimum of two (one in each direction of travel) is required. See installation manual for more information.

Loops and Loop Detectors

See Section A1, page 48 for a complete list of all loop detectors, prefabricated loops and loop accessories available.

Slide Gate Accessories

Heavy-Duty V-Wheel Assemblies

The tandem and quad wheel assemblies are designed for extremely heavy gates. The tandem and quad assemblies distribute the gate weight across a wider area of the gate track. A critical component of these very heavy gates is the track that the gate rolls on. **The track must be of a hardened material capable of supporting these extreme weights.**

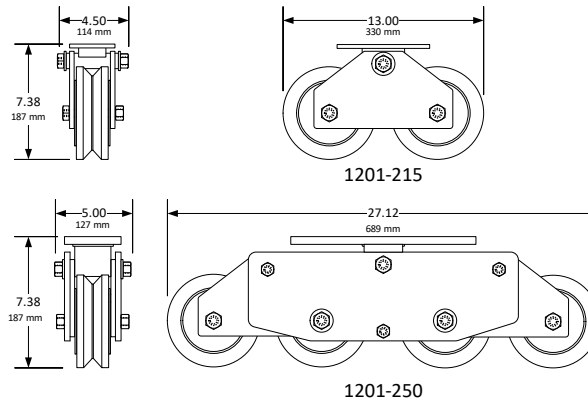

Heavy-Duty V-Wheel Assemblies

6-Inch (152 mm) Heavy-Duty Tandem V-Wheel Assembly
 1201-215 Steel w/sealed bearings.....844.50

- Assembly is rated for 7,000 lb (3,175 Kg). Maximum gate weight is 14,000 lb (6,350 Kg) - two (2) assemblies required per gate. **With this configuration, each wheel (4 total) is supporting 3,500 lb (1,587 Kg).**

6-Inch (152 mm) Heavy-Duty Quad V-Wheel Assembly
 1201-2502,451.00

- Assembly is rated for 14,000 lb (6,350 Kg). Maximum gate weight is 28,000 lb (12,700 Kg) - two (2) assemblies required per gate. **With this configuration, each wheel (8 total) is supporting 3,500 lb (1,587 Kg).**

Heavy-Duty Replacement V-Wheel

6-Inch (152 mm) Heavy-Duty Replacement V-Wheel
 1202-000 Steel w/sealed bearings 405.00

- 3500 Lb. (1587 Kg) maximum weight

1620 Lane Barrier - Red

Traffic Control Automated Barrier

The 1620 Lane Barrier is NOT a crash rated device. It is intended to provide a formidable barrier to help prevent passenger cars and light-duty pickup trucks from breaching a standard parking arm operator system. These lane barriers are not a stand-alone product, they are designed to be mechanically linked to and connected to the 1603-580 lane barrier operator. Required items; 1620-xxx lane barrier, 1603-580 lane barrier operator and octagonal aluminum arm components are ordered separately.

Caution: Installation and use of lane barriers in areas that are subject to freezing weather with potential for snow and ice accumulation is not recommended.

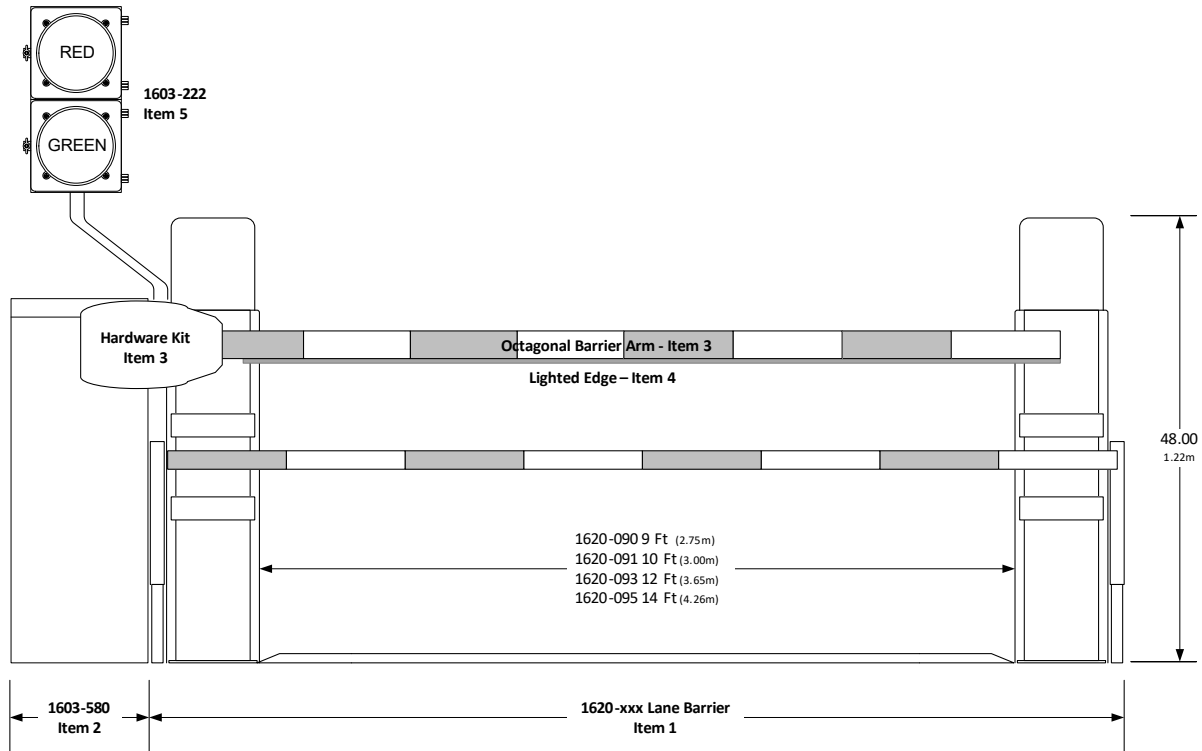

P/N	Lane Opening	Overall Dimensions (Item 1 + Item 2)		
		Height	Width	Depth
1620-090	9 Ft.	48 In.	13 Ft., 6 In.	5 Ft.
1620-091	10 Ft.	48 In.	14 Ft., 6 In.	5 Ft.
1620-093	12 Ft.	48 In.	16 Ft., 6 In.	5 Ft.
1620-095	14 Ft.	48 In.	18 Ft., 6 In.	5 Ft.

1. The 1620 Lane Barrier IS NOT a stand-alone product. It must be used with the 1603-580 Lane Barrier Operator.
2. 1620 Lane Barrier is not crash rated.
3. Traffic signal kit (1603-222) MUST be installed with the 1620 system.
4. Must use octagonal barrier arm (1601-555 or 1601-567) and 8080-096 Red/Green Reverse Edge Kit with this lane barrier.
5. Lane barrier anchor posts are finished in gloss cardinal red.
6. Designed for use with passenger cars and light trucks.

WARNING! LTL Carriers are now charging additional fees for any shipment that is eight (8) feet in length or greater. These fees can be substantial.

1620 Lane Barrier - Red

Traffic Control Automated Barrier

1620 Lane Barrier system components are ordered à la carte. Besides the lane barrier (ITEM 1), the lane barrier operator (ITEM 2), octagonal arm assembly (ITEM 3), lighted edge (ITEM 4), traffic signal (ITEM 5) and pedestrian protection (ITEM 6) must also be ordered to complete the system.

Lane barrier components are finished in Gloss Cardinal Red. 1603-580 lane barrier operator is finished in Gloss White.

ITEM 1: 1620 Lane Barrier¹ – Cardinal Red

1620-090 Lane Opening 9 Ft (2.75m).....	26,100.00
1620-091 Lane Opening 10 Ft (3.00m).....	26,400.00
1620-093 Lane Opening 12 Ft (3.65m).....	27,600.00
1620-095 Lane Opening 14 Ft (4.26m).....	28,800.00

1. Width shown is the distance between the post anchors.

ITEM 2: Lane Barrier Operator

1603-580 Lane Barrier Operator	4,185.00
2600-266 High Voltage Kit ²	Note 1

- 1. See Section A1, page 9 for pricing.
- 2. Allows operator to be powered from 208, 230 or 460 VAC.

ITEM 3: Octagonal Arm Components

1601-555 Arm 14 Ft (4.27 m).....	Note 1
1601-567, 2-piece ²	Note 1
1601-235 Hardware Kit ³	Note 1

- 1. See Section A1, page 11 for pricing.
- 2. Ships in 8-ft (2.4m) long box to reduce shipping cost.
- 3. Required.

ITEM 4: Lighted Edges

8080-306 Reverse Edge 6 Ft Lighted ^{2,3}	Note 1
8080-309 Reverse Edge 9 Ft Lighted ^{2,3}	Note 1
8080-096 Reverse Edge 12 Ft Lighted ^{2,3}	Note 1

- 1. See Section A1, page 11 for pricing.
- 2. LED Green (Up) and Red (Down)
- 3. Edge must be at least 2-Ft shorter than the overall arm length.

ITEM 5: Traffic Signal

1603-222 Traffic Signal 12 VDC w/35" Post	Note 1
1. See Section A1, page 9 for pricing.	

ITEM 6: Pedestrian Protection

8080-057 Photo-Reflective Beam.....	Note 1
9411-010 Loop Detector	Note 1

- 1. See Section A1, page 9 for pricing.

1625 Wedge Barrier - Red

Crash Rated Traffic Control Automated Wedge

The 1625 Wedge Barrier is crash rated to the ASTM F2656-20 standard. Wedges are intended to provide a formidable barrier to help prevent passenger cars and light-duty pickup trucks from breaching a standard parking arm operator system. These wedge barriers are not a stand-alone product, they are designed to be mechanically linked to and connected to a 1602-590 operator.

Caution: Installation and use of wedge barriers in areas that are subject to freezing weather with potential for snow and ice accumulation is not recommended.

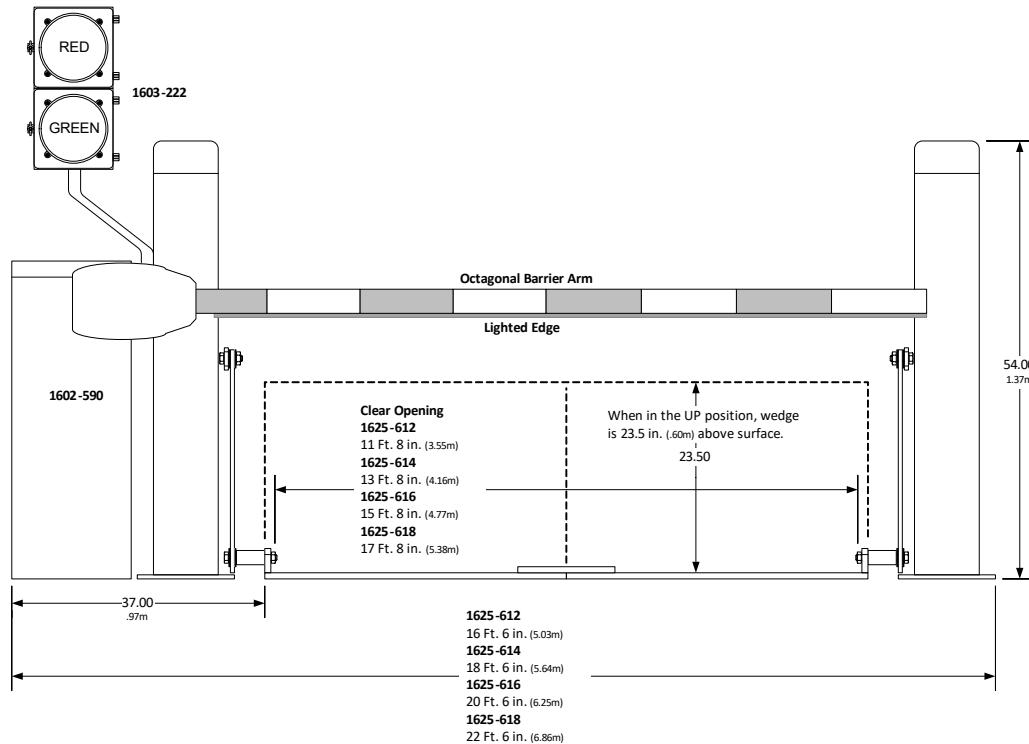

P/N	Lane Opening	Overall Dimensions (Wedge + Post + Operator)			Crash Rating
		Height	Width	Depth	
1625-612	11 Ft., 8 In.	54 In.	16 Ft., 6 In.	5 Ft., 8 In.	PU-30-P1
1625-614	13 Ft., 8 In.	54 In.	18 Ft., 6 In.	5 Ft., 8 In.	PU-30-P2
1625-616	15 Ft., 8 In.	54 In.	20 Ft., 6 In.	5 Ft., 8 In.	PU-30-P2
1625-618	17 Ft., 8 In.	54 In.	22 Ft. 6 In.	5 Ft., 8 In.	PU-30-P2

- 1625 Wedge Barriers ARE NOT a stand-alone product. They must be used with a 1602-590 Operator.
- Traffic signal kit (1603-222) MUST be installed with the 1625 system.
- Use 14 Ft. arm with 12 and 14 Ft. wedges and 17 Ft. arm with 16 and 18 Ft. wedges (17 Ft. arm can be used with the 14 Ft. wedge if desired).
- Wedge barrier is finished in gloss cardinal red.
- Designed for use with passenger cars and light trucks and will stop a vehicle up to 5,070 Lb at 30 MPH when installed per the manufacturer's installation instructions.

WARNING! LTL Carriers are now charging additional fees for any shipment that is eight (8) feet in length or greater. These fees can be substantial.

1625 Wedge Barrier - Red

Traffic Control Automated Wedge

1625 Wedge Barrier system components are ordered à la carte. Besides the wedge barrier (ITEM 1), the wedge barrier operator (ITEM 2), octagonal arm assembly (ITEM 3), lighted edge (ITEM 4), traffic signal (ITEM 5) and pedestrian protection (ITEM 6) must also be ordered to complete the system.

Wedge barrier components are finished in Gloss Cardinal Red. 1602 operator is finished in Gloss White.

ITEM 1: 1625 Lane Barrier¹ – Cardinal Red

1625-612 Lane Opening 12 Ft (3.65m).....	31,500.00
1625-614 Lane Opening 14 Ft (4.26m).....	34,500.00
1625-616 Lane Opening 16 Ft (4.87m).....	37,500.00
1625-618 Lane Opening 18 Ft (5.48m).....	40,500.00

1. Width shown is the distance between the post anchors.

ITEM 2: Operator

1602-590 Operator	4,875.00
2600-266 High Voltage Kit ²	Note 1

1. See Section A1, page 13 for pricing.

2. Allows operator to be powered from 208, 230 or 460 VAC.

ITEM 3: Octagonal Arm Components

1601-555 Arm 14 Ft (4.27 m).....	Note 1
1601-567, 2-piece ²	Note 1
1602-303 3 Ft (.91 m) Arm Extension ³	Note 1
1601-235 Hardware Kit ⁴	Note 1

1. See Section A1, page 11 for pricing.

2. Ships in 8-ft (2.4m) long box to reduce shipping cost.

3. Use with 14, 16 and 18 ft wedges.

4. Required.

ITEM 4: Lighted Edges

8080-096 Reverse Edge 12 Ft Lighted ²	Note 1
8080-315 Reverse Edge 15 Ft (4.57 m) Lighted ³	Note 1

1. See Section A1, page 11 for pricing.

2. LED Green (Up) and Red (Down)

3. Use with 17 Ft. arms.

ITEM 5: Traffic Signal

1603-222 Traffic Signal 12 VDC w/35" Post	Note 1
1. See Section A1, page 9 for pricing.	

ITEM 6: Pedestrian Protection

8080-057 Photo-Reflective Beam.....	Note 1
9411-010 Loop Detector	Note 1

1. See Section A1, page 9 for pricing.

Blank Page