



Owner's Manual

Supplemental Instructions for Series 1600, 6000, 9000 Vehicular Gate Operators with Convenience Open

DoorKing, Inc.
120 Glasgow Avenue
Inglewood, California 90301
U.S.A.
Phone: 310-645-0023
Fax: 310-641-1586
www.doorking.com

Use this manual as a supplement to and with the manuals included in the following models

1601, 1602, 1603 Barrier Gate Operators, 6100, 6300, 6500 Swing Gate Operators, 9150, 9310 Slide Gate Operators.

DoorKing, Inc. reserves the right to make changes in the products described in this manual without notice and without obligation of DoorKing, Inc. to notify any persons of any such revisions or changes. Additionally, DoorKing, Inc. makes no representations or warranties with respect to this manual. This manual is copyrighted, all rights reserved. No portion of this manual may be copied, reproduced, translated, or reduced to any electronic medium without prior written consent from DoorKing, Inc.

Important Notices

This manual is used as a supplement to the installation instructions that are provided with the vehicular gate operator. This manual references only the convenience open system and its connections to the vehicular gate operator. Refer to the operator installation manual for all other instructions.

The optional convenience open system installed in your vehicular gate operator is designed as a convenience enhancement only. It is not designed or intended to provide continuous gate operation during a power outage. Its sole purpose is to provide a method to open the vehicular gate to allow unimpeded traffic flow when the gate and access control system is without power.

If your access control system requires 100% power backup and continuous operation when primary (AC) power has failed, a power inverter / backup system, such as DoorKing's Model 2000, is required.

- The convenience open system cannot provide continuous gate operation during a power outage.
- Operation of this system is limited to cycling the gate to the open (up) position one time only.
- The convenience open system requires testing on a monthly basis to insure the batteries are fully charged and that the system is operational.
- The convenience open system uses two 12-volt, 3.0 amp-hour gel-cell batteries. These batteries should be replaced every two years on average, or sooner if required.
- Batteries are affected by temperature. Cold temperatures will reduce the effectiveness of the batteries and the backup system. High temperatures will result in a shortened battery life.
- Batteries are not covered under warranty.
- This system cannot be used with slide gate operators that are configured in the Fail-Secure mode.

1.1 Operating Modes

This convenience open system consist of a control board (2340-010), motor and power supply (batteries) providing a completely redundant drive system to open the gate should a power outage occur. This system is not designed to maintain continuous gate operation; rather it provides a convenient method to open a gate during adverse conditions. If continuous gate and access control system operation is required, refer to the DoorKing Model 2000 Inverter / Backup Power System.

When installed in slide or swing gate operators, the system can be set to operate in either a manual (for residential applications) or automatic (for apartment complexes, gated communities, etc.) mode of operation. The system will only operate in automatic mode when installed in a barrier gate operator.

Manual Mode – Residential Only

Manual mode (does not apply to 1601, 1602, 1603, 6500 or 9310 models) is designed for residential applications only. In manual mode (switch 1 OFF), the system will not open the gate if a power failure occurs until a manual input, either from a wired push button or RF transmitter, is received. This allows the gate to remain closed upon a loss of AC power, but provides a method to open the gate when desired. In manual mode of operation, the RF receiver is connected directly to the system's control board and is powered by this board (see page 20). During normal operation, when the relay in the radio receiver closes (a valid transmitter code has been received), this "signal" is passed through the system control board through terminal 4 and is feed directly to the gate operator main control board open input. If a power failure occurs, the radio receiver is powered from the batteries maintaining its operation. When a valid RF transmitter code is received under these conditions, the control board signals the DC motor to start and the motor will run for the set run time. A switch closure (push button) across terminals 1 and 2 on the control board will have the same result.

NOTE: The RF transmitter will open the gate provided that a stand-alone type receiver is in use. If the gate system uses a receiver that outputs the transmitter code in weigand format to an access controller (such as DoorKing models 1833, 1835, 1837 or 1838), then opening the gate from the RF transmitter under power outage conditions will not be possible with this system.

Automatic Open – Apartment Complexes, Gated Communities, Etc.

In automatic mode (switch 1 ON), the system will automatically open the gate or raise the barrier arm approximately 2-3 seconds after a loss of AC power. Automatic mode is always used for gates in general access applications such as gated communities, apartment complexes, etc. **Automatic mode must be used with 1601, 1602, 1603, 6500 and 9310 operators.**

Automatic Restart

Once AC power is restored, the system's control board can be set to automatically "re-key" the gate operator (switch 3 ON) to establish normal operation, or can be set to require an input (switch 3 OFF) before the gate operator resumes normal operation.

1.2 Adjustments

The DIP-switch located on the 2340 circuit board is used to setup the system for the type of operator it is installed in, and to program how the system will respond when a power outage occurs.

SWITCH	FUNCTION	SETTING	DESCRIPTION
1	Operation	OFF ON	Residential applications. Gate will remain closed when a power outage occurs. A radio receiver input or switch closure across terminals 1 and 2 will cause the gate to run to the open position. Apartment complexes, gated communities, etc. Gate will automatically open when a power outage occurs. Switch must be ON for 1601, 1602, 1603, 6500 and 9310 operators.
2	Direction	OFF ON	Set so that the gate runs to the open (up) direction upon loss of AC power.
3	Automatic Power-up Activation	OFF ON	When AC power is restored, an input (push button, loop, radio receiver, etc.) is required to return the gate to normal operation. When AC power is restored, a 1-second pulse is sent to the gate operator input to automatically restore normal operation.
4	Operator Type	OFF ON	Slide and swing gate operators only. 1601, 1602, 1603, 6500 and 9310 operators only.
5	NOT USED	OFF	
6	NOT USED	OFF	
7	NOT USED	OFF	
8	NOT USED	OFF	

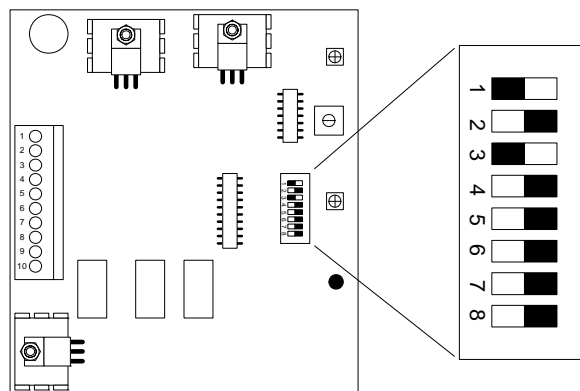

RUN TIMER

The run timer (see next page) sets the amount of time that the DC motor will run after it is activated from the 2340 circuit board. Adjust the run timer so that the gate opens to approximately six inches of the full open position and then shuts off. **Do not allow the DC motor to run long enough to slip the operator clutch or stall the DC motor. Damage to the circuit board may result from this condition.** Clockwise increases the run time, counter-clockwise decreases the run time.

NOTE: The run timer is not used when the system is installed in the 1601, 1602, 1603, 6500 or 9310 operators.

1.3 Terminal Description

1. COMMON
Common for open, radio receiver or open limit switch.
Note: Radio receiver cannot be connected when the system is installed in a 1601, 1602, 1603, 6500 or 9310 gate operator.
2. OPEN INPUT (LIMIT)
Open input.
(Open limit switch for 1601, 1602, 1603, 6500, 9310).
3. RADIO POWER
24 -Volt power for radio receiver (slide and swing gate operators only).
4. ACTIVATION OUTPUT
Radio relay activation or switch closure across terminals 1 and 2 will send an activation signal out of this terminal to the gate operator single-button activation input.
5. 24 VAC INPUT
6. 24 VAC COMMON
7. BATTERY POSITIVE INPUT
8. BATTERY NEGATIVE INPUT
9. DC MOTOR POSITIVE OUTPUT
10. DC MOTOR NEGATIVE OUTPUT

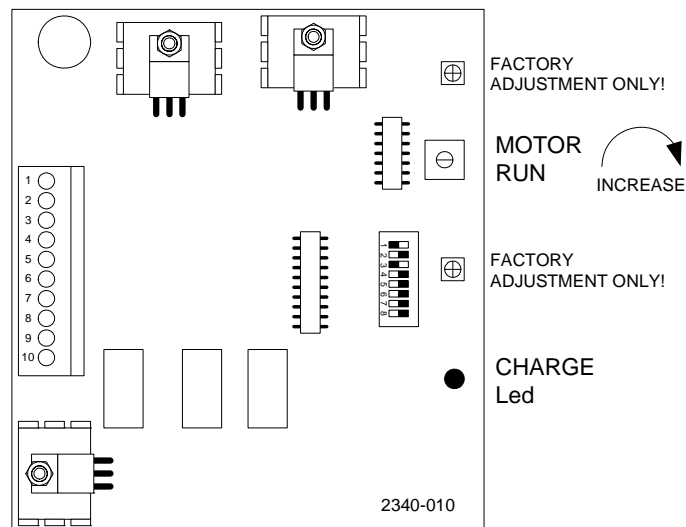

2.1 Model 6100, 6300 Swing Gate Operators

2.1.1 Single Operator

- For general access applications, be sure that the auto-open feature is turned on. **Set switch 1 to the ON position.**
- Connect a normally open push-button to terminals 1-2 on the 2340 control board. This allows another method to open the gate when a power outage occurs if the auto-open feature is not used.
- Do not power any other devices from the 2340 control board. All other gate activating devices (card readers, keypads, telephone entry, etc.) should be connected to the gate operator terminal strip as indicated in the operator installation manual.
- Emergency vehicle access device outputs should be connected to terminals 1-2 on the 2340 control board. This will enable emergency vehicle access provided that the emergency access device has its own backup power supply and is operational.

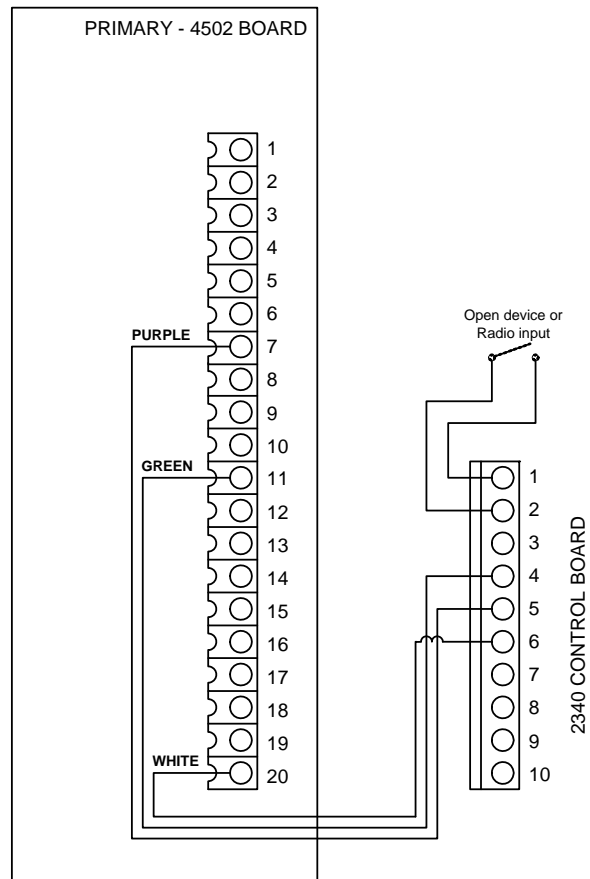

2.1.2 Bi-Parting Operators

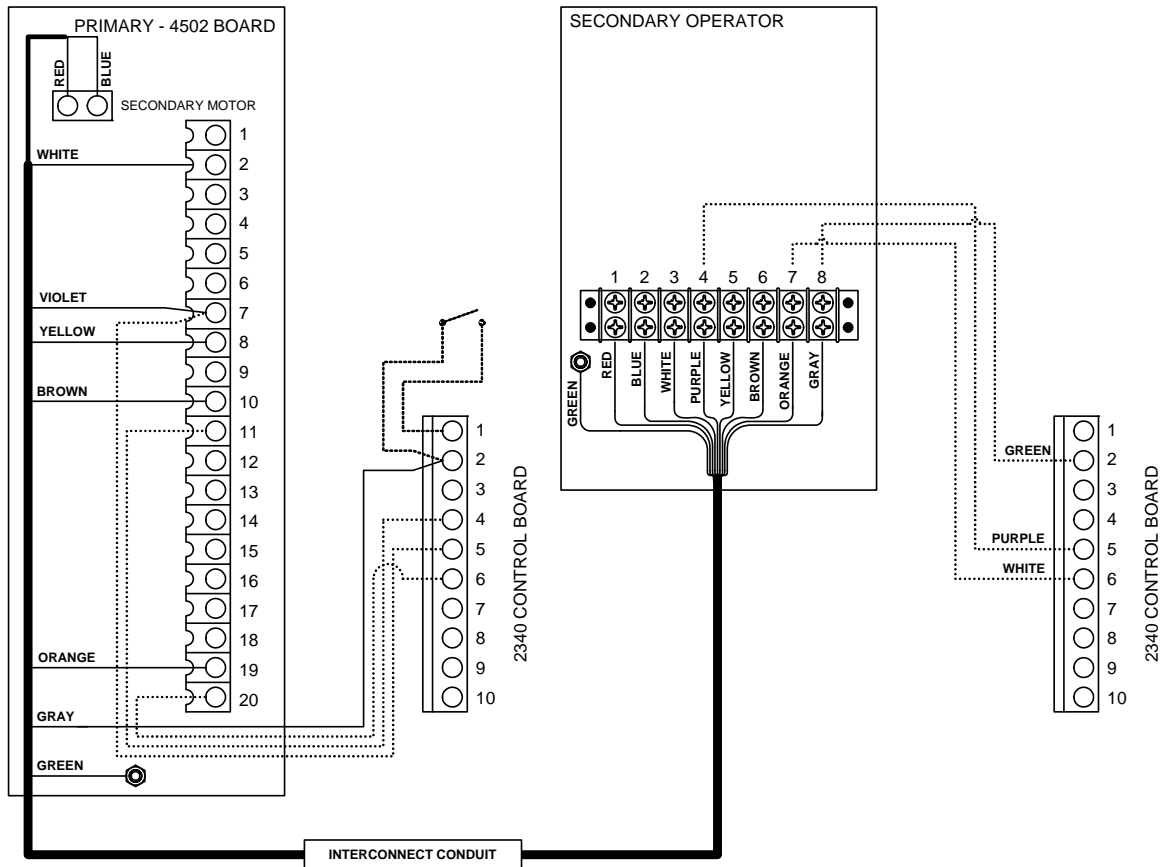

- Wire swing gate bi-parting operators as shown in Figure 2. Color code shown assumes the use of DoorKing interconnection cable. Order part number 2600-755 (30 ft.), 2600-756 (40 ft.), 2600-757 (50 ft.).
- Place a jumper wire from main circuit board terminal 19 to terminal 20 in the secondary operator only.
- The gray wire that connects the 2340 circuit board terminals 2 to each other is not required if the auto-open feature is turned on.
- See swing gate operator installation manual for connection of secondary entrapment protection devices.

2.2 Model 6500 Swing Gate Operators

2.2.1 Single Operator

- The auto-open feature must be turned on when the convenience open system is used in the 6500 swing gate operator. **Be sure switch 1 is in the ON position.**
- **Switch 4 must be in the ON position.** This causes the 2340 circuit board to look for the open limit switch installed in the operator.
- When a power outage occurs, the swing gate will automatically go to the full open position.

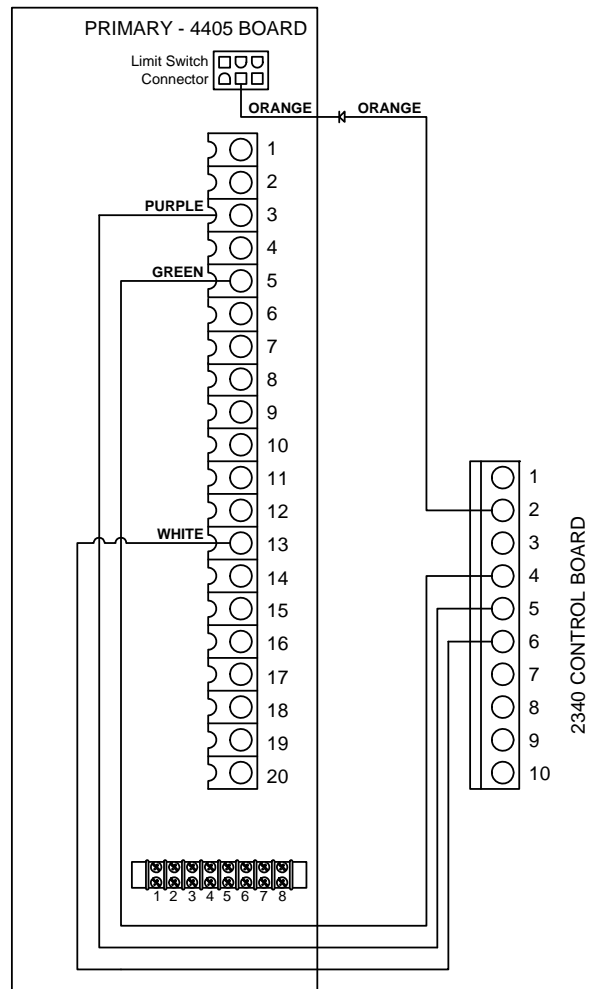

2.2.2 Bi-Parting Operators

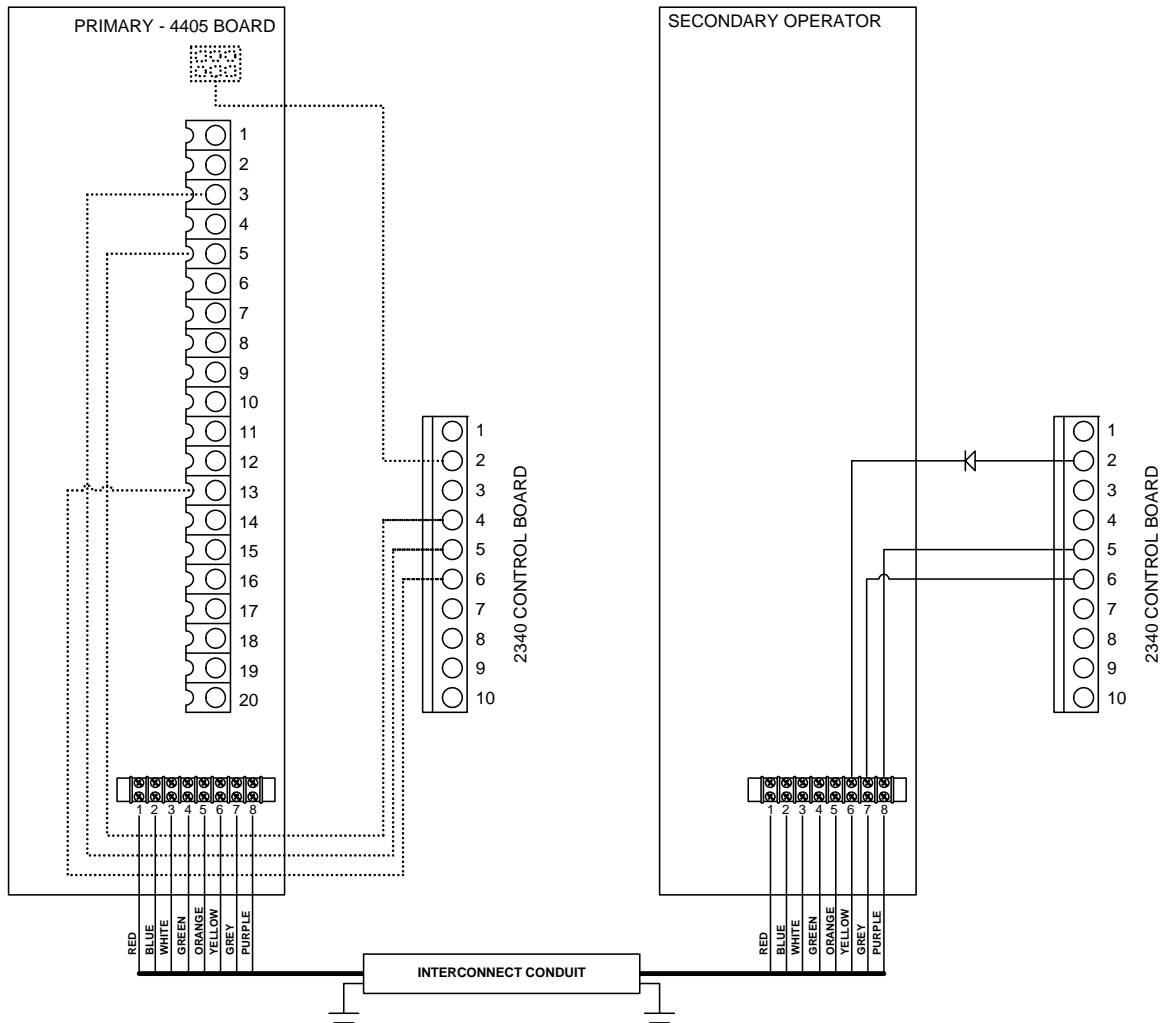

- Wire swing gate bi-parting operators as shown in Figure 4. Color code shown assumes the use of DoorKing interconnection cable. Order part number 2600-755 (30 ft.), 2600-756 (40 ft.), 2600-757 (50 ft.).
- See swing gate operator installation manual for connection of secondary entrapment protection devices.

2.3 Model 9150 Slide Gate Operators

2.3.1 Single Operators

- For general access applications, be sure that the auto-open feature is turned on. **Set switch 1 to the ON position.**
- Connect a normally open push-button to terminals 1-2 on the 2340 control board. This allows another method to open the gate when a power outage occurs if the auto-open feature is not used.
- Do not power any other devices from the 2340 control board. All other gate activating devices (card readers, keypads, telephone entry, etc.) should be connected to the gate operator terminal strip as indicated in the operator installation manual.
- Emergency vehicle access device outputs should be connected to terminals 1-2 on the 2340 control board. This will enable emergency vehicle access provided that the emergency access device has its own backup power supply and is operational.

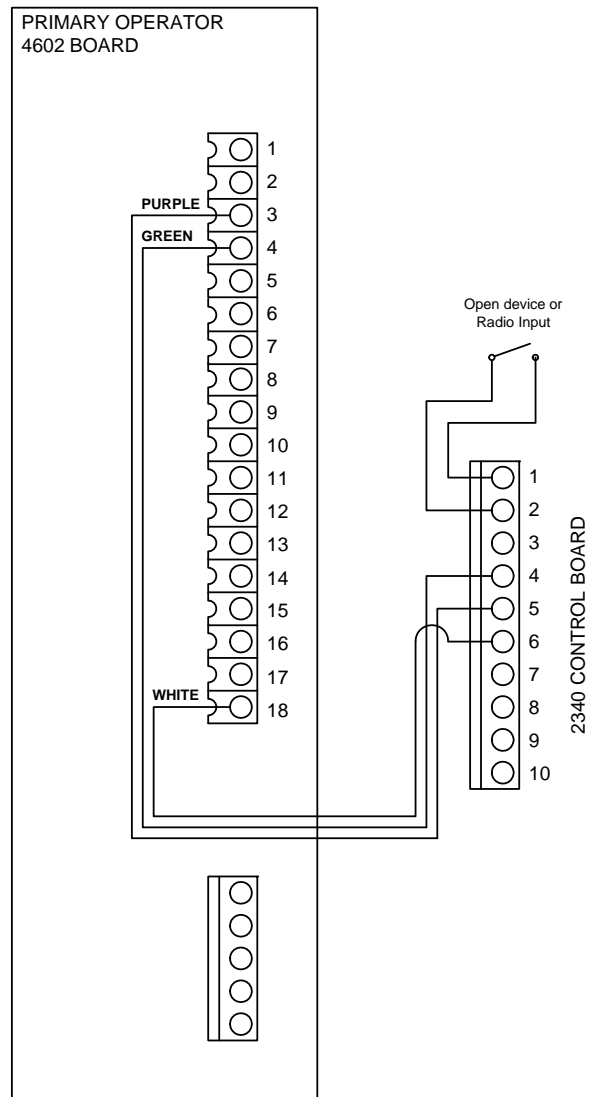

2.3.2 Bi-Parting Operators

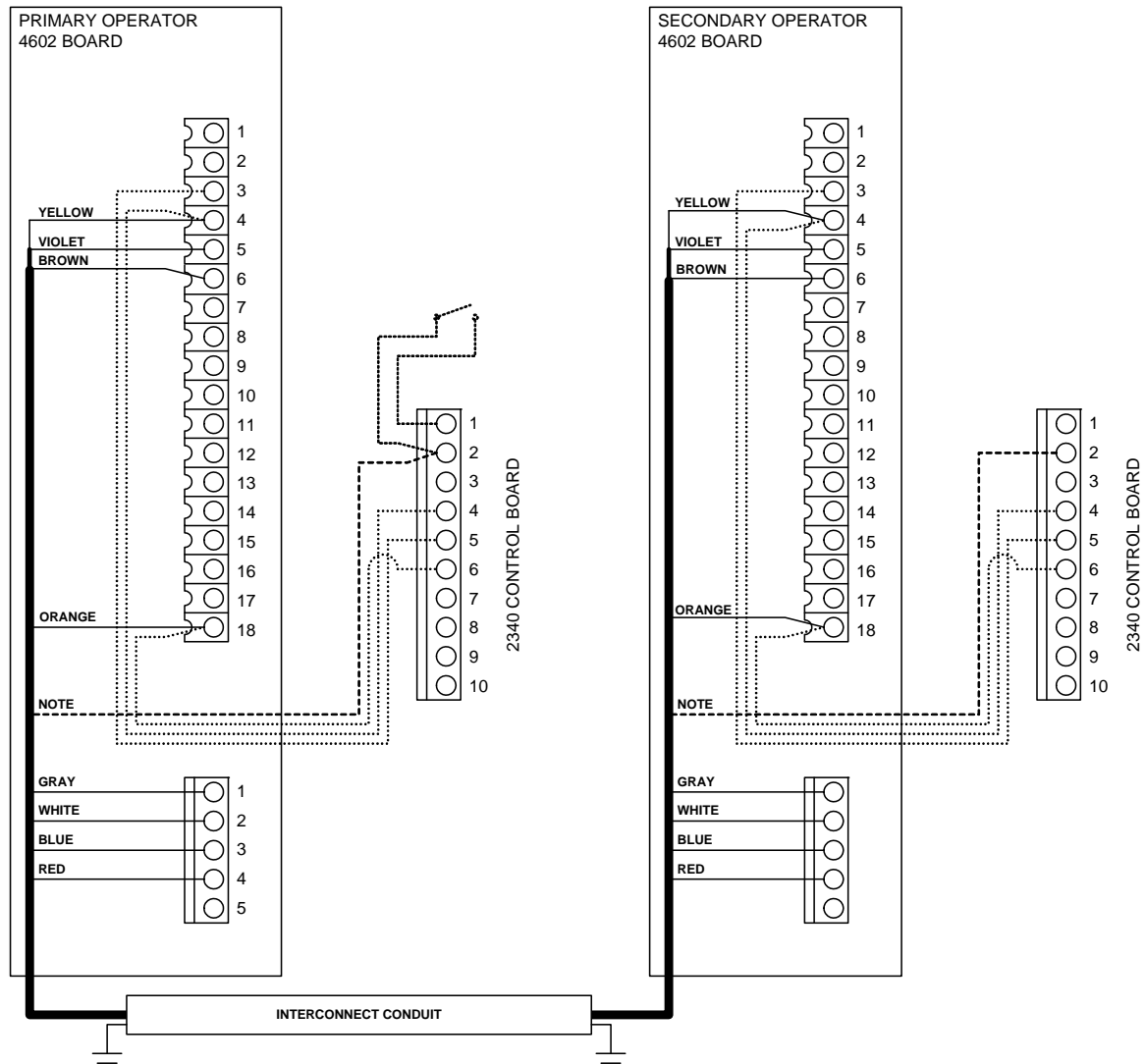

- Slide gate systems use two primary operators rather than a primary/secondary combination to create bi-parting slide gates. Wire slide gate operators as shown in Figure 6. Color code shown assumes the use of DoorKing interconnection cable. Order part number 2600-755 (30 ft.), 2600-756 (40 ft.), 2600-757 (50 ft.).
- Be sure to connect the auxiliary terminals on the 4602 board as shown (gray, white, blue, red wires). This assures that activation of a secondary entrapment device will stop or reverse both gates.
- See slide gate operator installation manual for connection of secondary entrapment protection devices.
- **NOTE:** If the auto-open feature is not used, an additional wire will need to be run in the interconnection conduit. With this wire, connect terminal 2 on the 2340 circuit boards to each other.

2.4 Model 9310 Slide Gate Operators

2.4.1 Single Operators

- The auto-open feature must be turned on when the convenience open system is used in the 9310 slide gate operator. **Be sure switch 1 is in the ON position.**
- **Switch 4 must be in the ON position.** This causes the 2340 circuit board to look for the open limit switch installed in the operator.
- When a power outage occurs, the slide gate will automatically go to the full open position.

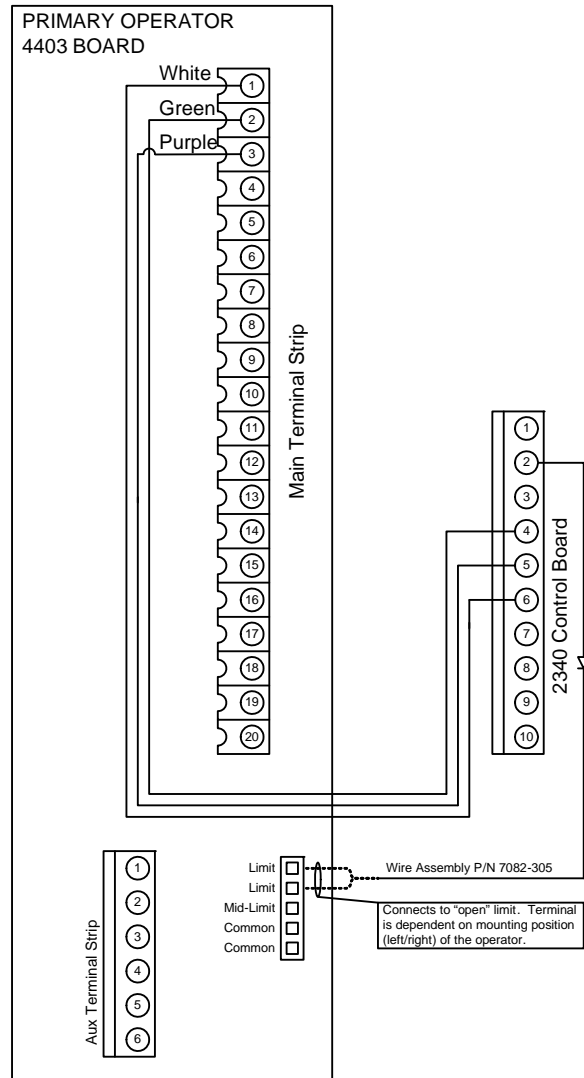

2.4.2 Bi-Parting Operators

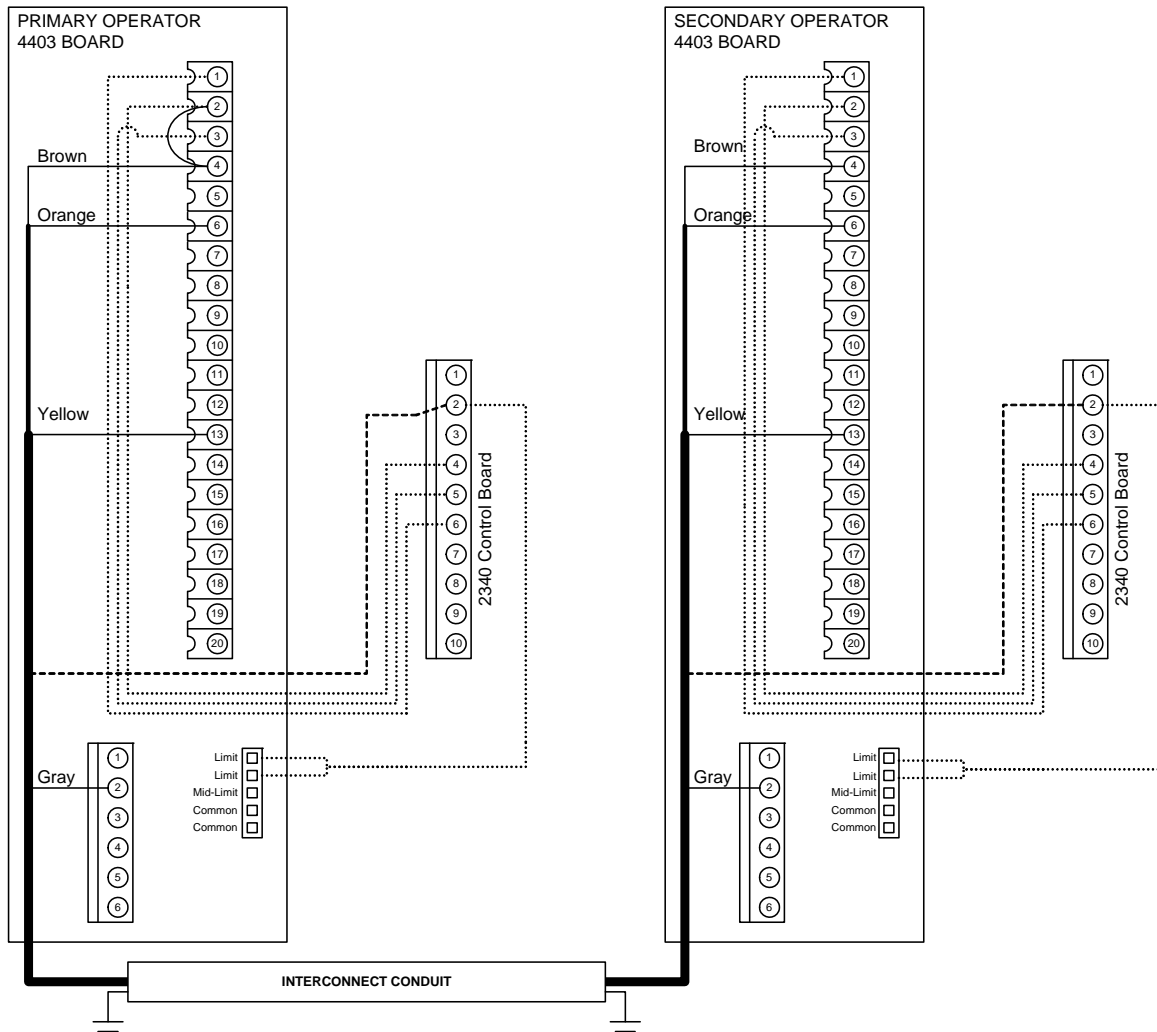

- Slide gate systems use two primary operators rather than a primary/secondary combination to create bi-parting slide gates. Wire slide gate operators as shown in Figure 8. Color code shown assumes the use of DoorKing interconnection cable. Order part number 2600-755 (30 ft.), 2600-756 (40 ft.), 2600-757 (50 ft.).
- Be sure to connect the auxiliary terminal (CLS PHOTO) on the 4403 board as shown). This assures that activation of a secondary entrapment device will stop or reverse both gates.
- See slide gate operator installation manual for connection of secondary entrapment protection devices.
- **NOTE: If the auto-open feature is not used, an additional wire will need to be run in the interconnection conduit. With this wire, connect terminal 2 on the 2340 circuit boards to each other.**

2.5 Model 1601, 1602, 1603 Barrier Gate Operators

2.5.1 Single Operators

- The auto-open feature must be turned on when the convenience open system is used in the 1601, 1602 or 1603 barrier gate operators. **Be sure switch 1 is in the ON position.**
- **Switch 4 must be in the ON position.** This causes the 2340 circuit board to look for the up magnetic limit switch installed in the operator.
- When a power outage occurs, the barrier arm will automatically raise to the up position.

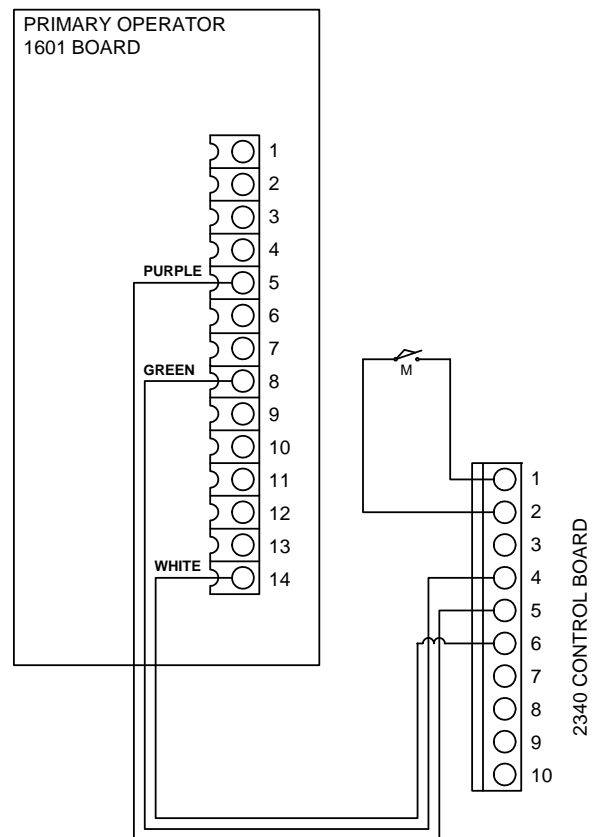

2.5.2 Bi-Parting Operators

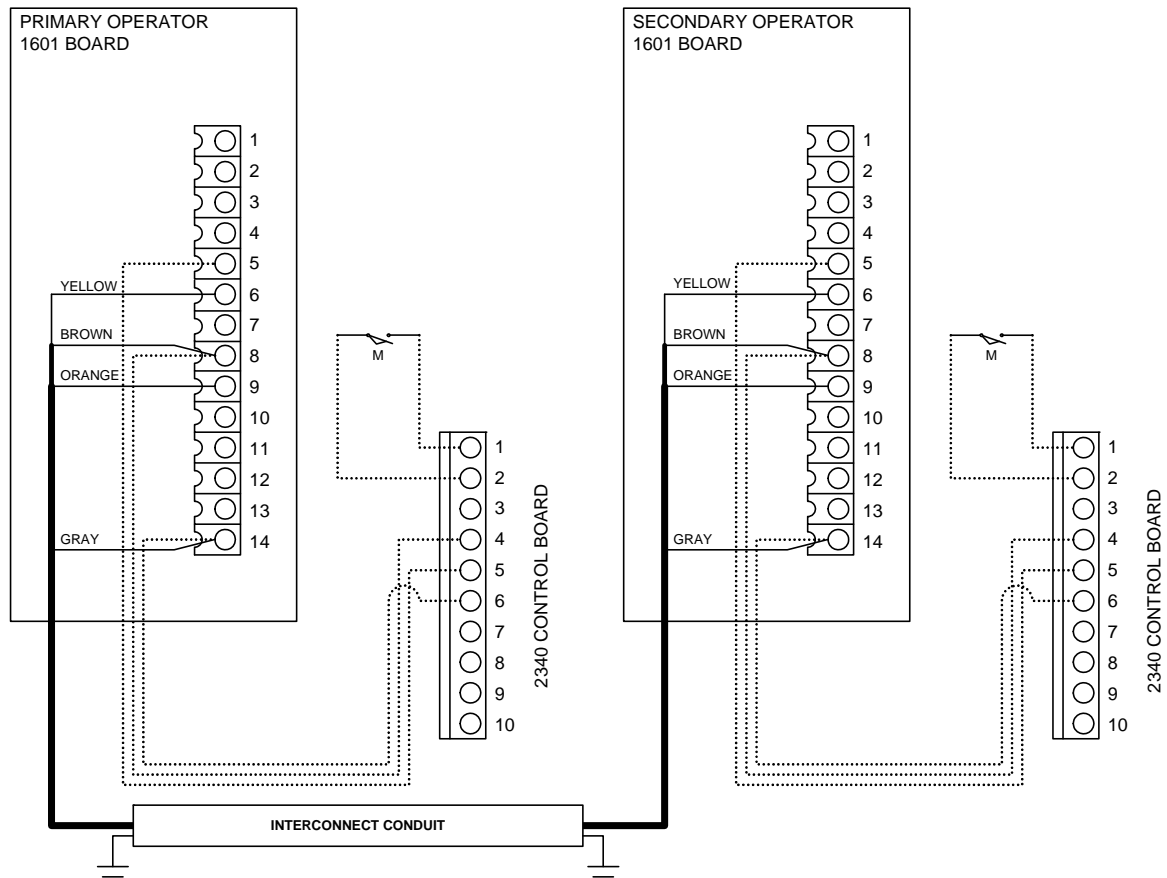

- Barrier gate systems use two primary operators for bi-parting barrier gate systems. Wire barrier gate operators as shown in Figure 10. Color code shown assumes the use of DoorKing interconnection cable. Order part number 2600-755 (30 ft.), 2600-756 (40 ft.), 2600-757 (50 ft.).

2.6 Residential Applications

Note: Residential applications described here cannot be used with the 1601, 1602, 1603, 6500 or 9310 operators. These operators must be set with the auto-open feature (switch 1) turned ON.

Convenience open systems used in residential applications may use an RF receiver to open the gate upon a power outage rather than the auto-open feature that is used in general access applications. This allows the residential gate to remain closed until it receives a command to open from the radio receiver. **To disable the auto-open feature, set switch 1 to the OFF position.**

- If RF transmitters are used to open the access gate, connect the radio receiver to terminals 1-2-3 on the 2340 control board as shown in Figure 9. Terminal-1 is RADIO RECEIVER COMMON, Terminal-2 is the RELAY CONTACT, terminal-3 is RADIO RECEIVER POWER.
- Connecting the radio receiver in this manner allows the receiver to be powered from the batteries during power outages. This will permit a transmitter to open the gate during a power outage if the auto-open feature is not used.
- If your gate access system uses an RF receiver that outputs the received transmitter data in weigand format to an external weigand controller, then the transmitter will not open the gate unless the weigand controller has its own backup power system to provide it with backup power when primary (AC) power fails.

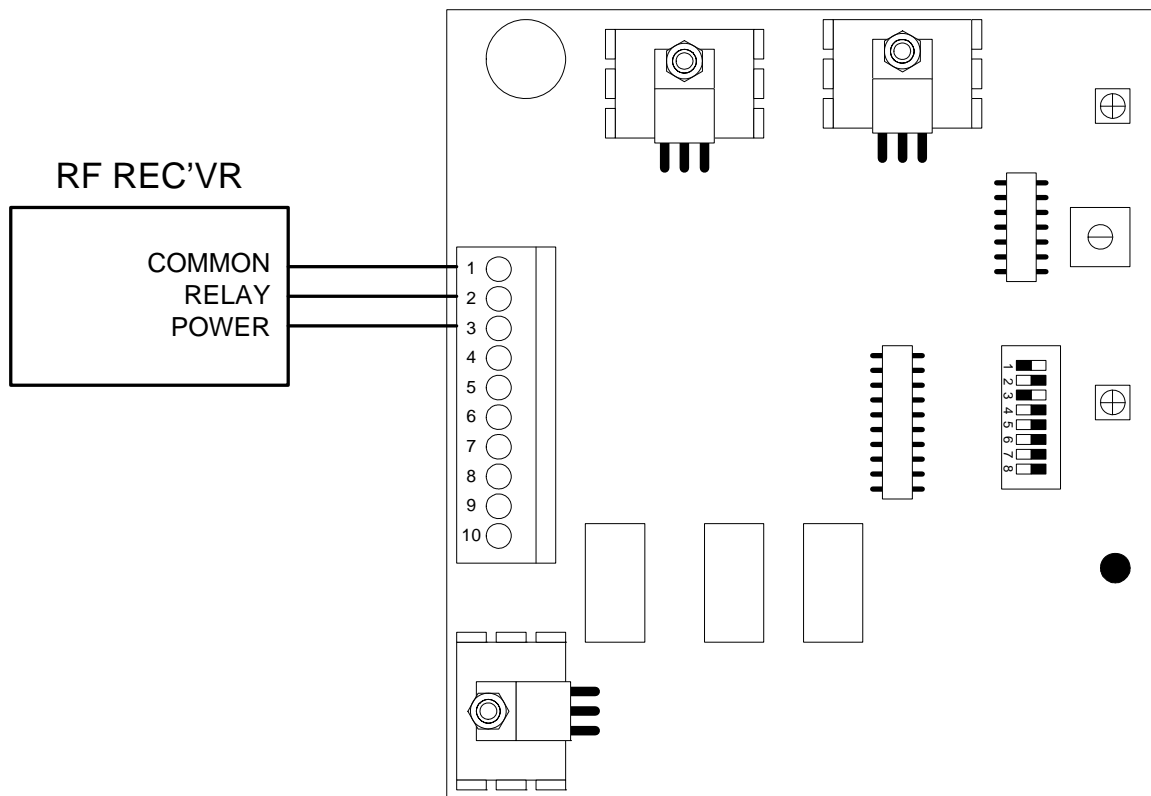

3.1 Wiring Diagram

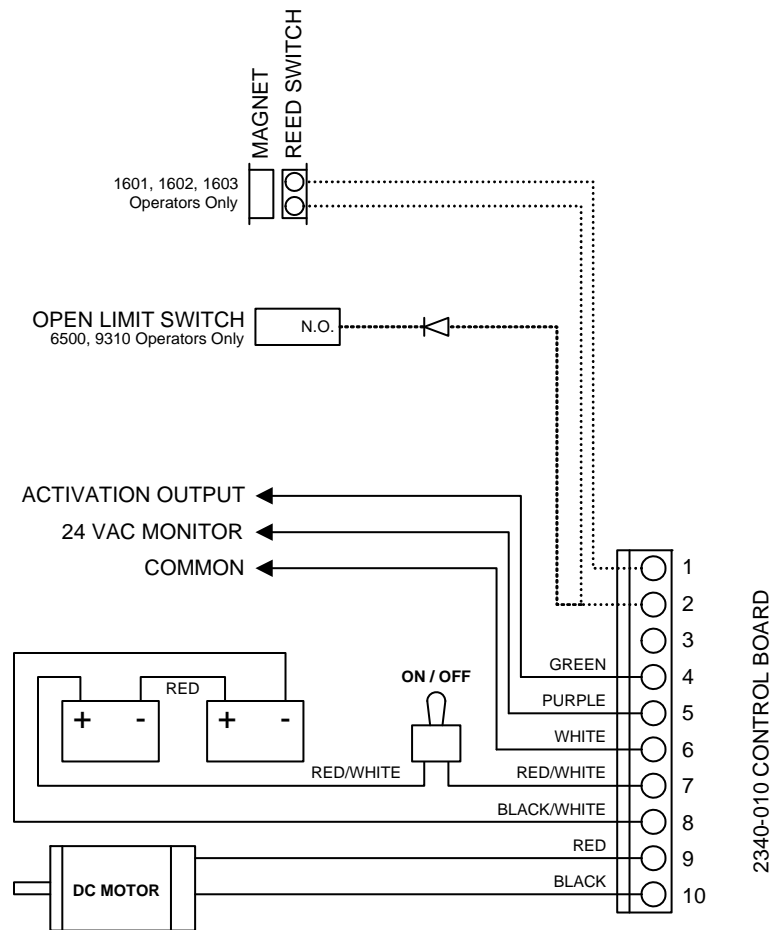

Part Number	Qty	Description
2340-010	1	Control Board
1801-009	2	Battery, 12 Volt, 3.0 Amp Hour
1601-041	1	Toggle Switch
2600-196	1	DC Motor Assembly
1601-253	1	Reed Switch, Barrier Operators Only
2600-817	1	Magnet, Barrier Operators Only
7082-305	1	Wire Assembly – 9310 Operators Only
2600-688	1	V-Belt (Not Shown)